

HEAT RECOVERY UNITS USER & INSTALLATION MANUAL

SHR-XXX

WARNING

If the supply cord is damaged, it must be replaced by the manufacturer or its service agent or a similarly qualified person in order to avoid a hazard.

An all-pole disconnection device which has at least 3mm separation distance in all pole and a residual current device(RCD)with the rating of above 10mA shall be incorporated in the fixed wiring according to the national rule.

Disconnect the power supply before cleaning and maintenance.

The appliance shall be installed in accordance with national wiring regulations.

This appliance can be used by children aged from 8 years and above and persons with reduced physical, sensory or mental capabilities or lack of experience and knowledge if they have been given supervision or instruction concerning use of the appliance in a safe way and understand the hazards involved.

Children shall not play with the appliance.

Cleaning and user maintenance shall not be made by children without supervision.

DISPOSAL: Do not dispose this product as unsorted municipal waste.

Collection of such waste separately for special treatment is necessary.

Directive 2002/96/EC (WEEE):

The symbol depicting a crossed-out waste bin that is underneath the appliance indicates that this product, at the end of its useful life, must be handled separately from domestic waste, must be taken to a recycling centre for electric and electronic devices or handed back to the dealer when purchasing an equivalent appliance



MAIN PARTS OF THE UNIT

SHR-200~SHR-400

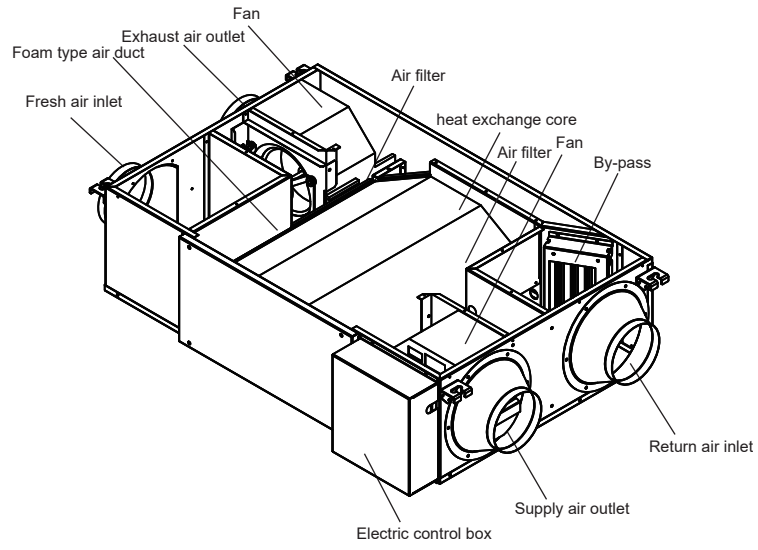

SHR-500~SHR-1000

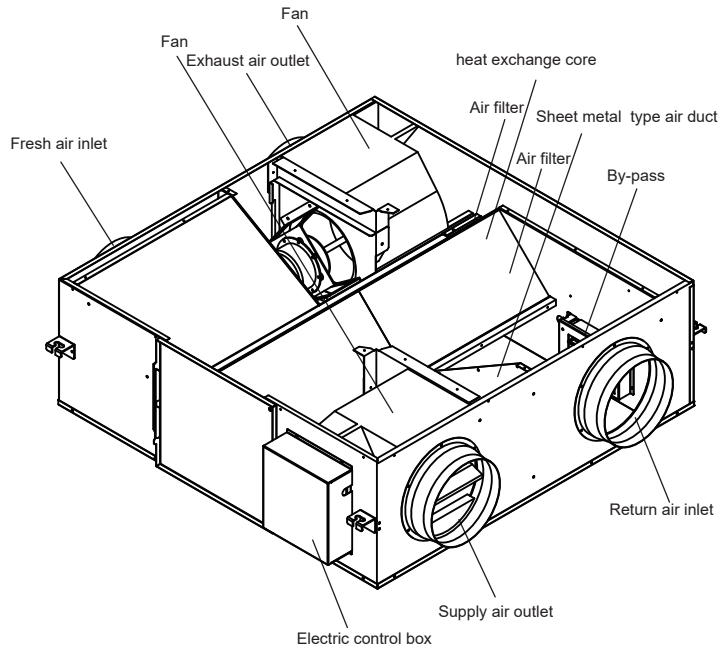

SHR-1500~SHR-2000

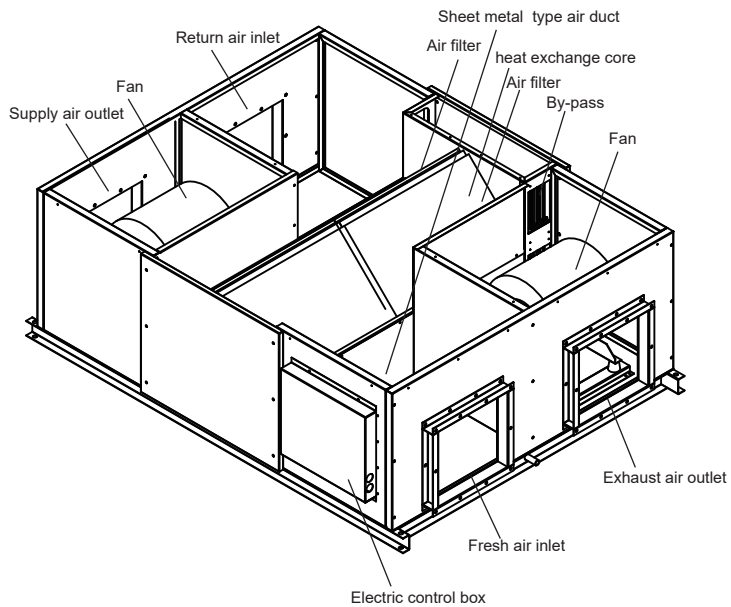

CONTENTS	PAGE
PRECAUTIONS.....	1
ACCESSORY.....	1
INSTALLATION.....	2
WIRING.....	6
SPECIFICATION PARAMETER.....	8
SHR APPLICATION.....	9
MAINTENANCE AND UPKEEP.....	9
TRAIL RUN.....	9
ERP INFORMATION.....	10

1. PRECAUTIONS

To prevent injury to the user or other people and property damage, the following instructions must be followed. Incorrect operation due to ignoring of instructions may cause harm or damage. The appliance should be installed by a professional in accordance with the specified instructions.

The safety precautions listed here are divided into two categories. In either case, important safety informations are listed which must be read carefully.



WARNING

Failure to observe a warning may cause electric shock, fire hazard or personal injury



CAUTION

Failure to observe a caution may cause injury or damage to the equipment.



WARNING

- Ask your dealer or qualified personnel to carry out installation work. Do not try to install the machine by yourself. incorrect installation may result in leakage, electric shocks or fire.
- Installation should be done by following the installation manual and no changes should be made to the unit. Incorrect installation may cause leakage, electric shock, or fire.injury may occur if the SHR falls.
- Install the unit on a foundation that is strong enough to withstand the weight of the unit. A foundation of insufficient strength may result in the equipment falling and causing injuries.
- Do not allow exhaust air to enter the outside air inlet. This may cause the air of the room to become contaminated, harming the health.
- Locate the outside air intake vent so that it does not take in exhaust air which contains combustion air, etc. Incorrect installation may cause a loss of oxygen in the room, leading to serious accidents.
- Make sure that a separate power supply circuit is provided for this unit and that all electrical work is carried out by qualified personnel according to local laws and regulations and this installation manual. An insufficient power supply capacity or improper electrical construction may lead to electric shocks or fire. Insufficient power supply capacity or incorrect wiring may cause electrical shocks or fire.

- Make sure Earth Leakage Breaker is the type of all poles drop-out.
- Be sure to ground. Do not connect the ground wire to gas or water pipes, lightning rod or a telephone ground wire. Incomplete grounding may result in electric shocks.
- Make sure that all wiring is secured, the specified wires are used, and no external forces act on the terminal connections or wires. Improper connections or installation may result in overheating or fore.
- When wiring the power supply and connecting the remote controller wiring and transmission wiring, position the wires so that the electric parts box lid can be securely fastened. Improper positioning of the electric parts box lid may result in electric shocks, fire or the terminals overheating.



CAUTION

- Be sure to install an earth leakage breaker. Failure to install an earth leakage breaker may result in electric shocks.
- Install the indoor and outdoor units, power supply wiring and connecting wires at least 1 meter away from television or radio in order to prevent image interference or noise. (Depending on the radio waves, a distance of 1 meter may not be sufficient enough to eliminate the noise.)
- Install the two outdoor ducts with down slope to prevent rainwater from entering the unit. If this is not done completely, water may enter the building, may damage furniture, etc.
- Insulate the duct and the wall electrically when a metal duct is to be penetrated through the metal lattice and wire lattice or metal lining of a wooden structure wall. Improper duct work may cause electric shocks or short circuits.
- Make sure that a snow protection measure is taken. If no protection snow may enter through the outdoor ducts, and cause damaging furniture and electric shock and fire.

2. ACCESSORY

Table 2-1

Name	Qty.	Shape	Purpose
Installation and owner's manual	1	This manual	must be delivered to the customer

Notes: Wired controller SWC-120G should be purchased separately.

Prepare the following on site.

Table 2-2

Name	Purpose
PVC drain pipe	For connecting unit's drain pipe, which length is selected according to your actual requirement (Model 1500, 2000 are available)
Damper	For vibration damping, when lift the unit.

3. INSTALLATION

3.1 Installation Preparation



WARNING

Keep all the accessories and tools until installation work is completed.

- Leave the unit inside its packaging while moving, until reaching the installation site. Where unpacking is unavoidable, use a sling of soft material or protective plates together with a rope when lifting, to avoid damage or scratches to the unit.
- Hold the unit by the hanger brackets when opening the crate and moving it, and do not lift it holding on to any other part (especially the duct connecting flange).



NOTE

Be sure to instruct customers how to properly operate the unit (especially maintenance of air filter, and operation procedure) by having them carry out operations themselves while looking at the manual.

3.2 Select The Installation Site



CAUTION

When moving the unit during or after unpacking, make sure to lift it by holding its hanger brackets. Do not exert any pressure on other parts, especially duct connecting flange.

- Select an installation site where the following conditions are fulfilled and meet with your customer's approval.
 - SHR should be installed far away from office, recreation or any other places where silent environment are required. (install that in special machine room or wash room is recommended)
 - install in a place which has sufficient strength and stability. (Beam, ceiling and other locations capable of fully supporting the weight of the unit.) Insufficient strength is dangerous. It may also cause vibration and unusual operating noise.
 - Do not install the unit directly against a ceiling or wall. (If the unit is in contact with the ceiling or wall, it can cause vibration.)
 - Where sufficient clearance for maintenance and service can be ensured.



CAUTION

- Install the units, power supply wiring and connecting wires at least 1 meter away from televisions or radios in order to prevent interference or noise. (Depending on the radio waves, a distance of 1 meter may not be sufficient enough to eliminate the electric interference.)
- The bellows may not be able to be used in some districts, so exercise caution. contact your local government office or fire department for details.
- When discharging exhaust air to a common duct, the Building Standard Law requires the use of fire proof materials, so attach a 2m copper plate standing duct.

- Do not install the unit in the following locations:
 - Place subjected to high temperature or direct flame. May result in fire or overheating.
 - Place such as machinery plant and chemical plant where gas, which contains noxious gas or corrosive components of materials such as acid, alkali organic solvent and plait, is generated. Place where combustible gas leakage is likely. Copper piping and brazed joints may corrode, causing refrigerant to leak or poisoning and fire due to leaked gas.
 - Place such as bathroom subjected to moisture. Electric leak or electric shocks and other failure can be caused.
 - Near machinery emitting electromagnetic waves. Electromagnetic waves may disturb the operation of the control system and result in a malfunction of the equipment.

3.3 Preparations Before Installation

- Confirm the positional relationship between the unit and suspension bolts. Leave space for servicing the unit and include inspection hatches. (Always open a hole on the side of the electric parts box so that the air filters, heat exchange elements, fans, be easily be inspected and serviced.)
- Make sure the range of the unit's external static pressure is not exceeded.
- Open the installation hole (Pre-setting ceilings) Once the installation hole is opened in the ceiling where the unit is to be installed, pass transmission wiring, and remote controller wiring to the unit's wiring holes. After opening the ceiling hole, make sure ceiling is level if needed. It might be necessary to reinforce the ceiling frame to prevent shaking. Please consult architect or woodworker, if necessary.
- Install the suspension bolts. (Use M10 to M12 suspension bolts.) Use a hole-in anchor, sunken insert anchor for existing ceilings, or other parts to be procured in the field to reinforce the ceiling to bearing the weight of the unit.
- Install vibration damping feet. (For vibration damping)

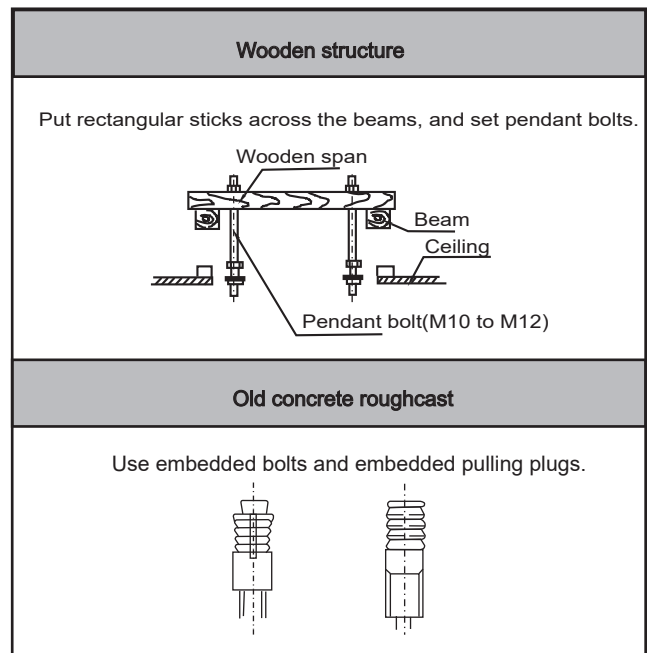

Fig. 3-1

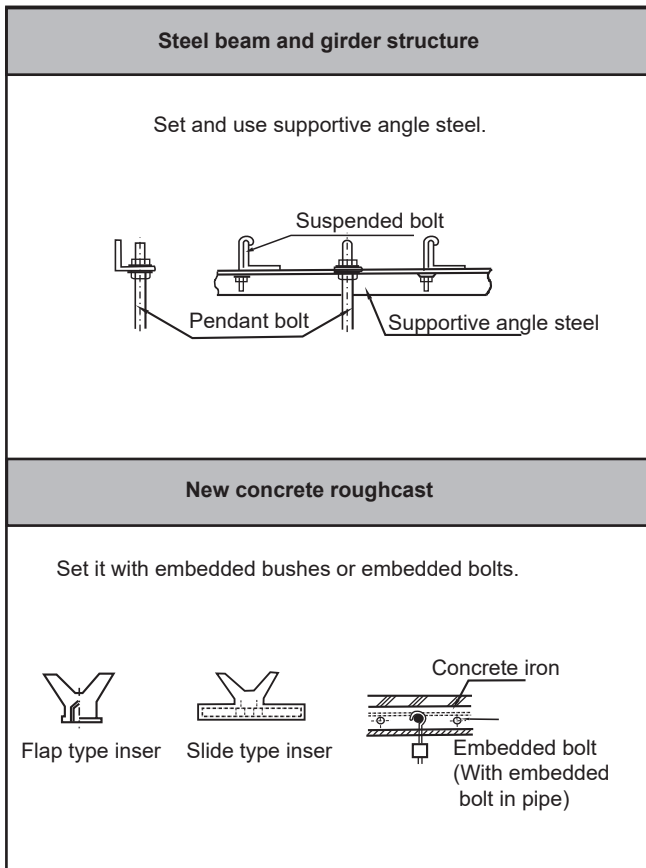

Fig. 3-2

3.4 Installation

- Before installation, please confirm all external parts are stand in their place and without damage.
- The surrounding environment of the unit, especially the sides of wiring cabinet and water collecting side should reserve sufficient wiring and maintenance space; additionally, one should ensure the removing space for filter griller.
- Unit should mount steadily and without sustain the weight form condensate water pipe and air duct. The vents of air inlet/outlet and return should be connected with flexible tube.
- Unit in AC 220-240V/50Hz、220-240V/60Hz、380-415V/50Hz or 220-240V/60Hz, reliable grounding; each one possesses of independent cut-off and protection device.
- The installation dimension and maintenance space. (See the following attached picture Fig.3-3)
- Operating conditions

For proper performance, run the air conditioner under the following temperature conditions:

OPERATION	Outdoor air TEMP.	-7 °C~43 °C
	Room TEMP.	-7 °C~43 °C
	Room humidity	Lower than 80% If higher than 80%, the surface of indoor unit may be condensed or the condensate will be blown from air outlet.

Protection or error may occur if running the unit beyond the above condition, and will cause unit stop running.

Unit: mm

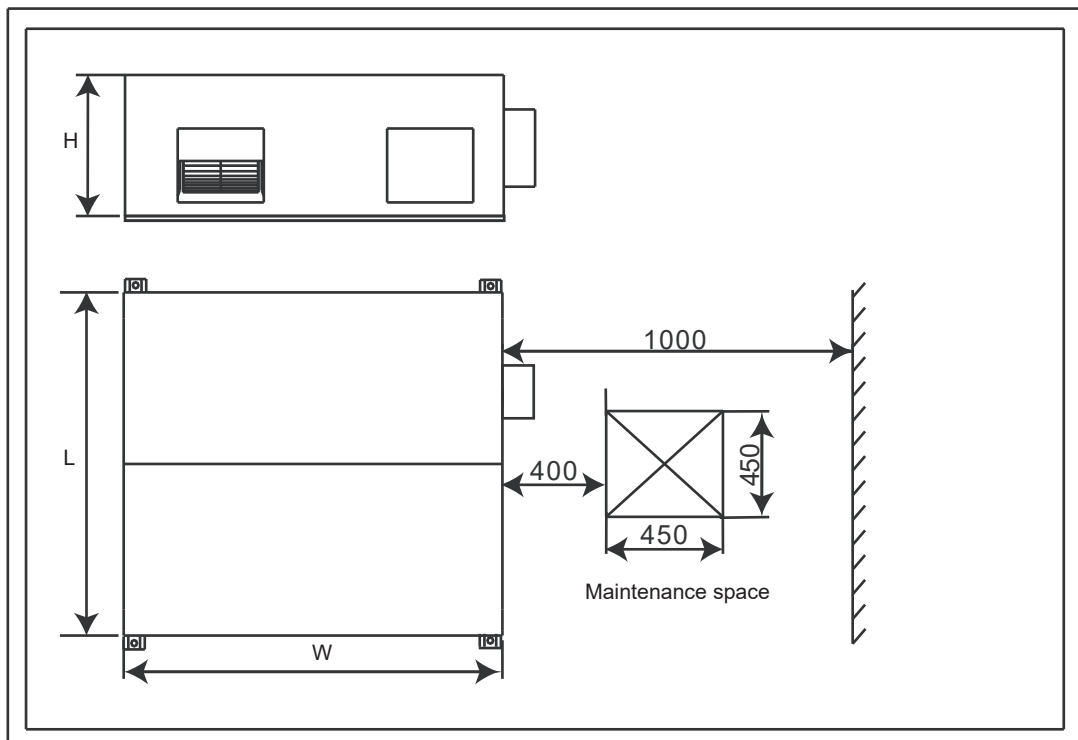

Fig. 3-3 Detail structure specification and maintenance space

Key dimensions of the unit and air duct installation. (See the following pictures Fig.3-4~3-7 & Table 3-1)

SHR-200~SHR-400

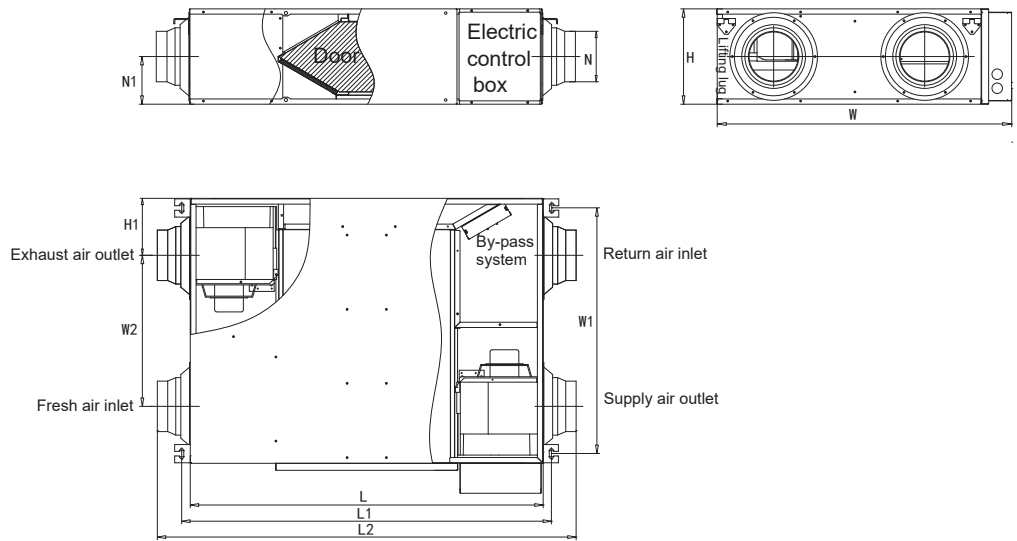

Fig. 3-4

SHR-500~SHR-1000

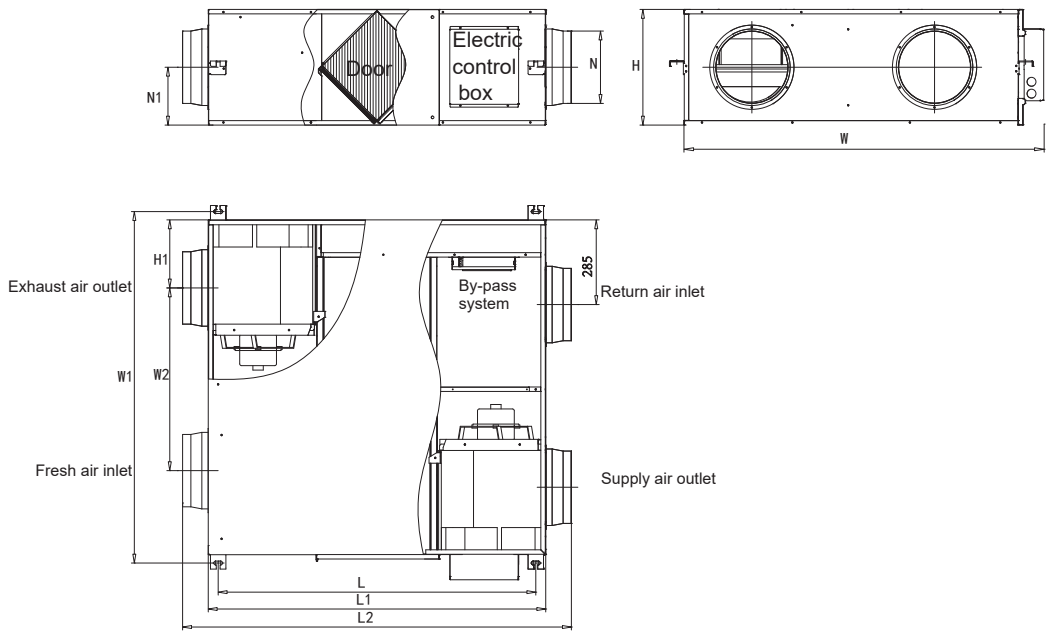

Fig. 3-5

Table 3-1 (Unit:mm)

Model	L	L1	L2	W1	W2	W	H	H1	N	N1
SHR-200	1007	1054	1195	588	356	801	272	142	Φ 144	136
SHR-300	1007	1054	1195	701	431	914	272	163	Φ 144	136
SHR-400	1081	1129	1276	991	595	1204	272	202	Φ 198	136
SHR-500	1071	1138	1311	1005	465	1106	390	227	Φ 244	195
SHR-800	1071	1138	1311	1185	616	1286	390	229	Φ 244	195
SHR-1000	1071	1138	1311	1431	764	1526	390	230	Φ 244	195

SHR-1500

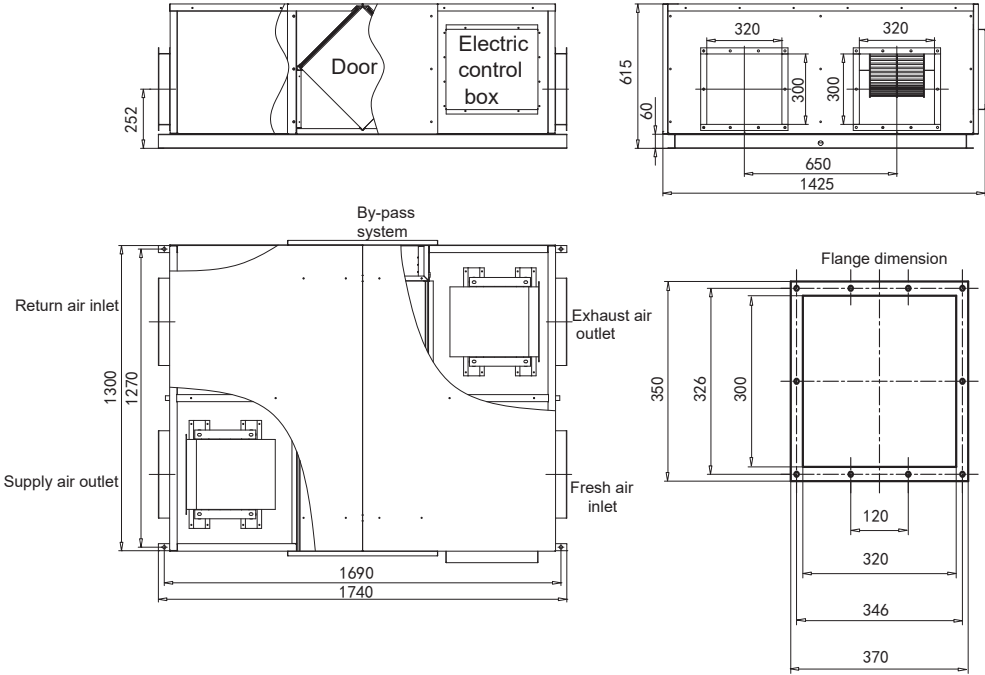

Fig. 3-6

SHR-2000

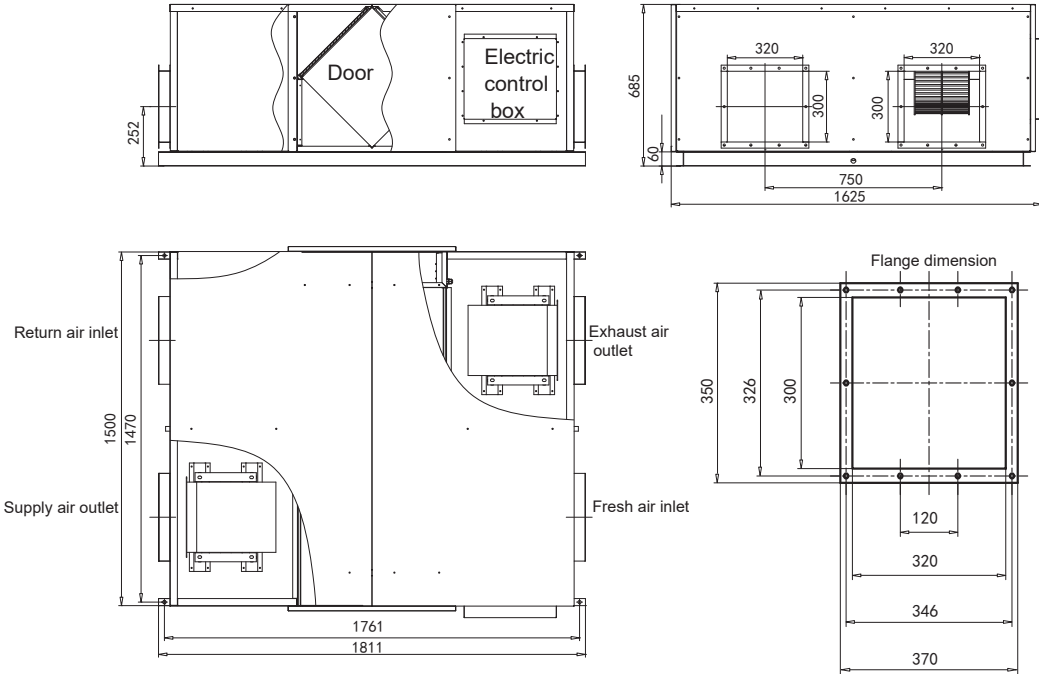

Fig. 3-7

4. WIRING

⚠ Warning

- All the supplied parts, materials and electrical works must comply with local regulations.
- Only use copper wires.
- Use a steady power supply for the air-conditioners. The power voltage must be in line with the rated voltage.
- The electrical wiring works must be carried out by a professional technician, and must comply with the labels stated in the circuit diagram.
- Before the electrical connection works are carried out, turn off the power supply to prevent injuries caused by electric shock.
- The external power supply circuit of the air conditioner must include an earth line, and the earth line of the power cord connecting to the indoor unit must be securely connected to the earth line of the external power supply.
- Leakage protective devices must be configured according to the local technical standards and requirements for electrical and electronic devices.
- The fixed wiring connected must be equipped with an all-pole disconnection device with a minimum 3 mm contact separation.
- The distance between the power cord and signal line must be at least 300 mm to prevent the occurrences of electrical interference, malfunction or damage to electrical components. At the same time, these line must not be in contact with the piping and valves.
- Choose electrical wiring that conforms to the corresponding electrical requirements.
- Connect to the power supply only after all the wiring and connections have been completed, and check carefully if the connection is correct.

figure of the power supply terminal

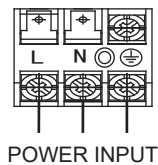

Fig. 4-1

When connecting to the power supply terminal, use the circular wiring terminal with insulation.

Use power cord that conforms to the specifications and connect the power cord firmly. To prevent the cord from being pulled out by external force, make sure it is fixed securely.

If circular wiring terminal with insulation cannot be used, please make sure that:

- Do not connect two power cords with different diameters to the same power supply terminal (may cause overheating).

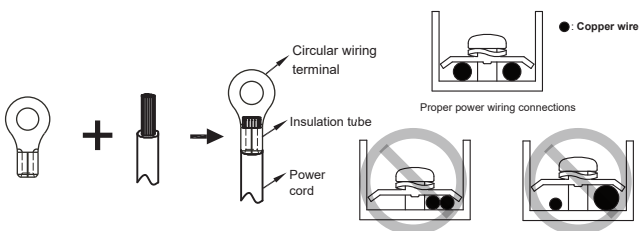

Fig. 4-2

Fig. 4-3

4.2 Electric data Specification

Table 4-1

Model SHR-200~2000		
Power supply	Phase	Signal phase
	Frequency /voltage	220-240V/50Hz
Input current Main switch /fuse(A)		15/30
Power supply wireDimension	Wire's qty	3 (Earthing line should be used yellow/green wire.)
	Code wire cross-section (mm ²)	2.5

- After wiring, please confirm all connections are correct, and then power to the unit.
- Pay attention to the power supply wire of three-phase model; confirm the phase sequence of which is correct.

Table 4-2

ENC1 Settings for Capacity SW1 Setting for static pressure

ENC1	Capacity setting
0	200
1	300
2	400
3	500
4	800
5	1000
6	1500
7	2000

SW1-1	ON	Low static pressure
	OFF	High static pressure
SW1-2	ON	SHR centralized control
	OFF	SHR single unit operation
SW2-1	ON	With PRO
	OFF	Without PRO
SW2-2	ON	Positive Pressure
	OFF	Navigation Pressure
SW2-3	ON	SW2-2
	OFF	Balance Pressure

⚠ Caution

- Dip switch settings have been configured in factory. Do not change settings on site.

Table 4-3 Code and Definitions

Operation lamp	Flash NO.	Show on centralized controller	Explanation
●	/	/	Unit is ON
○	/	/	Unit is OFF
★	2	E2	Indoor temperature sensor error
★	4	E5(new protocol) EF(old protocol)	Outdoor temperature sensor error
★	6	E7	EEPROM error
★	8	E6	DC fan motor error
★	10	OFF LINE	Without address
★	12	E1	Communication error with ODU
★	14	E9	wire controller communication failure
★	16	EU	error with sensor board
★	18	FC	error with CO2 sensor

NOTE: ●:Light ; ○:Extinguish ; ★:Quick flash

Table 4-4 Terminal Definition

CODE	CN8	CN9	CN32	CN33	CN7	CN3	CN4	CN21
NAME	Q P E	Y X E	RxTxE	D2D1E	X1X2	Indoor temp. Sensor	Outdoor temp. Sensor	PRO

Dry contact (Out put)	CN31	Inlet air pre-heat Signal
	CN16	Force to exhaust air
	CN26	Remote ON/OFF
Dry contact (In put)	CN14	Signal for inlet air Pre-heat
	CN15	Alarm
	CN20	Signal for ventilation fan

4.3 System connection diagram

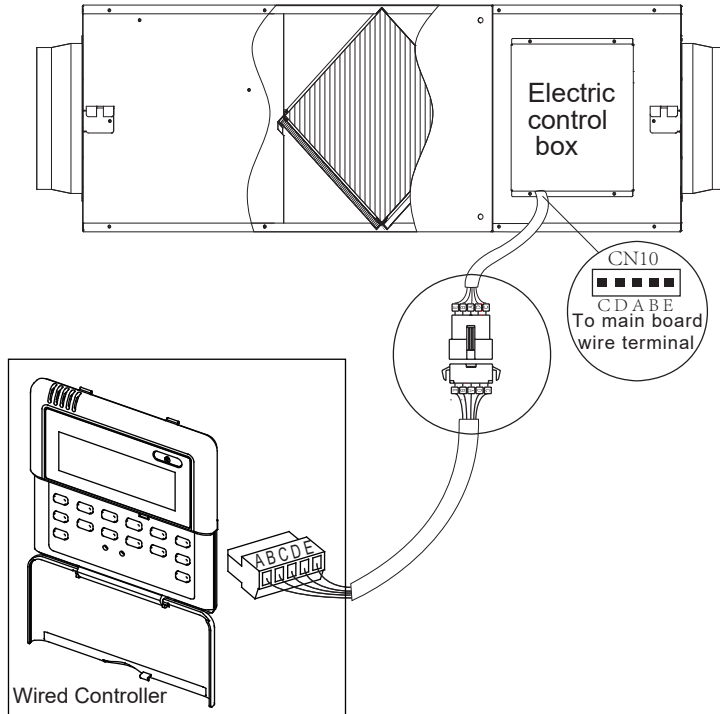

Fig. 4-4

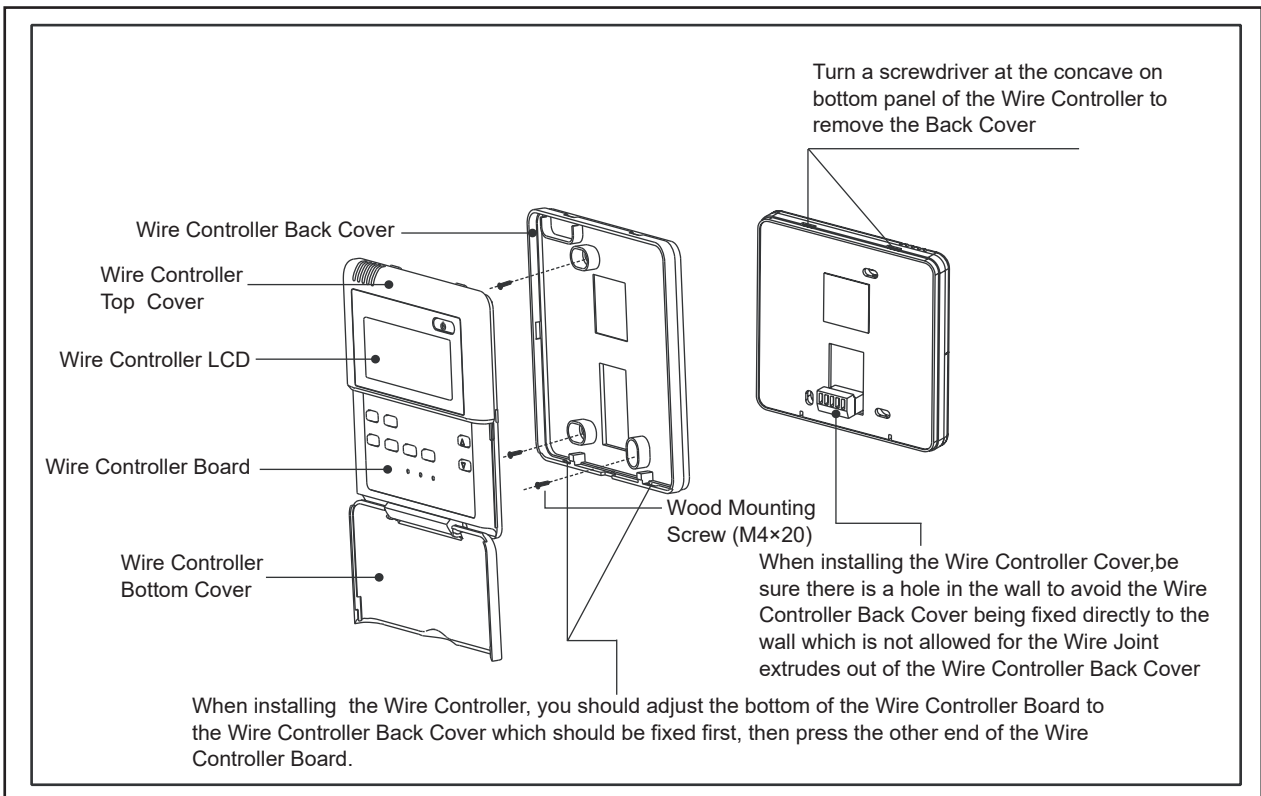

Fig. 4-5



CAUTION

1. Never turn screws too tightly, or else the cover would be dented or the Liquid Crystal breaks.
2. Please leave enough space for maintain and upkeep the wire controller.
3. Wired controller SWC-120G should be purchased separately.

5. SPECIFICATION PARAMETER

5.1 Specification Parameter

Table 5-1

Model	Power supply	Packing size(mm)	Air outlet dimension (mm)	Net weight (kg)	Static pressure (Pa)	Nominal air flow (m ³ /h)
SHR-200	220-240V~ 50Hz	1275×880×420	Φ 144	46.5	100	200
SHR-300		1275×994×420	Φ 144	56.5	90	300
SHR-400		1360×1284×420	Φ 198	71.5	100	400
SHR-500		1390×1244×540	Φ 244	76	90	500
SHR-800		1390×1424×540	Φ 244	80	140	800
SHR-1000		1390×1670×540	Φ 244	90	160	1000
SHR-1500		1830×1520×770	346×326	181.5	180	1500
SHR-2000		1900×1720×845	346×326	208.5	200	2000

Table 5-2

Model	Nominal temp. efficiency	Nominal enthalpy efficiency	Sound power level(dB)	Power input(kW)	Current(A)
SHR-200	81.1	77.5	45	0.07	0.64
SHR-300	75.5	72.1	48	0.10	0.84
SHR-400	77.7	73.5	48	0.11	0.97
SHR-500	80.6	74.0	50	0.15	1.2
SHR-800	78.7	72.3	55	0.32	2.4
SHR-1000	82.8	76.0	54	0.38	2.9
SHR-1500	75.5	69.4	69	0.68	3.8
SHR-2000	77.2	74.7	70	0.95	5.7

Notes:

There are 3 steps of fan speed (High, Medium, Low), all the parameters in the above table is measured at the high speed.

6. SHR APPLICATION

6.1 Operation principle

SHR (Heat Recovery Ventilation) employ advanced technique and technics, the heat exchanged core forming by special paper that be processed with chemical treatment, which could create the optimum result in temperature, humidity and cooling recovery.

High efficiency heat exchanged core: When air flow formed by exhaust air and outdoor air through the heat exchanged core in cross way, because of temperature difference in the two sides of flat partition board, the heat transmission is occurred. In summer, outdoor air acquire cooling from air exhaust to decrease environment temperature; In winter, outdoor air acquire heat from air exhaust to increase temperature, that is to say, it realizing the energy recovery during air exhaust process to exchange the heat in heat exchanged core to outdoor air.

6.2 Pay Attention To The Following Items Before Operation

- 6.2.1. Before drive-up, please clean up the duct and check whether all air valves and devices are normal.
- 6.2.2. Carefully adjust the system air valves when start-up, control the current of motor in rated range.
- 6.2.3. Three-phase model without by-pass function, therefore the fan would delay 30 seconds to start up.
- 6.2.4. Connect the wired controller
Wired controller should be installed according to wired controller owner's manual, installation manual (Attached in the package box in wire controller).

7 MAINTENANCE AND UPKEEP

- 7.1 During early use, one should check the fan operation regularly.
- 7.2 The cleaning regulation for air filter depend on local environment. It could be clean by vacuum dirt exhauster or water, if heavy dust accumulates, it should use neutral detergent to clean it, and then dry it in shady and cool place for 20 to 30 minutes and replace it.
- 7.3 Clean the core at least 2 years a time by vacuum dirt exhauster to remove dust and foreign substance in the unit assemblies, do not touch the assemblies by exhauster and flush by water to avoid core damage.
- 7.4 Check the fan every half a year to maintain the well balance of it and check whether the axletree has loosed.

8. TRIAL RUN

8.1 Please Confirm The Following Points Before Trial Run:

- 8.1.1 The unit is installed correctly completed.
- 8.1.2 Ducting and wiring are correctly completed.
- 8.1.3 The drainage is smooth.
- 8.1.4 The heating insulation works well.
- 8.1.5 The ground wiring is connected correctly.
- 8.1.6 The power voltage fits the rated voltage of SHR.
- 8.1.7 There is no obstacle at the outlet and inlet of SHR.

8.2 Control The SHR By Wired controller, Operate It According To Wired controller Owner's Manual.

- 8.2.1 Whether the switch on the remote controller works well.
- 8.2.2 Whether the room temperature is adjusted well.
- 8.2.3 Whether the indicator lights normally.
- 8.2.4 Whether there is vibration or abnormal noise during operation.

9. ERP INFORMATION

Table 9-1

Fan Types	Centrifugal forward curved fan		
Directive (or Standard) for Regulation	ErP Directive 2009/125/EC COMMISSION REGULATION (EU) No 327/2011		
Model Name	WZDK170-38G-2 +LX-245*203*12-48J 1320	Rev.	
Prepare by			

Specified Information of Fan:

No.	Information Item	Comment
1	$\eta_{\text{target}}=$	32.5%
2	Overall efficiency(η_e)=	33.02%
3	Pass or not (Criteria: $\eta_e \geq \eta_{\text{target}}$)	Pass
4	Measurement category (A -D)	A
5	Efficiency category (static or total)	Static
6	Efficiency grade at optimum energy efficiency point	N =44.52
7	VSD is integrated within the fan	YES
8	Year of Manufacture	Ref. to the Unit Nameplate
9	Manufacturer' s name and place of manufacture	Ref. to the Unit Nameplate
10.1	Rated motor power input(s) (kW), at optimum energy efficiency	0.1517kw
10.2	Rated motor flow rate(s) at optimum energy efficiency	0.1614m3/s
10.3	Rated motor pressure(s) at optimum energy efficiency	270Pa
11	Rotations per minute (R.P.M)at the optimum energy efficiency point	1320r/min
12	Specific ratio	1.001
13	Information relevant for facilitating disassembly, recycling or disposal at end-of-life	all materials can be recycled
14	Information relevant to minimize impact on the environment and ensure optimal life expectancy as regards installation, use and maintenance of the fan	For installation, the clearance of 500 mm shall be kept from inlet
15	Description of additional items used when determining the fan energy efficiency, such as ducts, that are not described in the measurement category and not supplied with the fan.	Measurement category A, fan is free inlet and outlet conditions
16	Motor manufacturer	NIDEC SHIBAURA(ZHEJIANG)CORP.

Table 9-2

Fan Types	Centrifugal forward curved fan		
Directive (or Standard) for Regulation	ErP Directive 2009/125/EC COMMISSION REGULATION (EU) No 327/2011		
Model Name	WZDK750-38G-W-1+LX-261*234*15-48J 1300	Rev.	
Prepare by			

Specified Information of Fan:

No.	Information Item	Comment
1	$\eta_{\text{target}}=$	34.14%
2	Overall efficiency(η_e)=	49.7%
3	Pass or not (Criteria: $\eta_e \geq \eta_{\text{target}}$)	Pass
4	Measurement category (A -D)	A
5	Efficiency category (static or total)	Static
6	Efficiency grade at optimum energy efficiency point	N =59.51
7	VSD is integrated within the fan	YES
8	Year of Manufacture	Ref. to the Unit Nameplate
9	Manufacturer' s name and place of manufacture	Ref. to the Unit Nameplate
10.1	Rated motor power input(s) (kW), at optimum energy efficiency	0.276kw
10.2	Rated motor flow rate(s) at optimum energy efficiency	0.34m3/s
10.3	Rated motor pressure(s) at optimum energy efficiency	360 Pa
11	Rotations per minute (R.P.M)at the optimum energy efficiency point	1300r/min
12	Specific ratio	1.001
13	Information relevant for facilitating disassembly, recycling or disposal at end-of-life	All materials can be recycled
14	Information relevant to minimize impact on the environment and ensure optimal life expectancy as regards installation, use and maintenance of the fan	For installation, the clearance of 500 mm shall be kept from inlet
15	Description of additional items used when determining the fan energy efficiency, such as ducts, that are not described in the measurement category and not supplied with the fan.	Measurement category A, fan is free inlet and outlet conditions
16	Motor manufacturer	Panasonic Appliances Motor(Hangzhou)Co.Ltd.

Table 9-3 Required information for RVU in COMMISSION REGULATION (EU) No.1254/2014 ANNEX IV

No.	Information Item	Comment
1	Supplier's name	Sinclair
2	Model name	SHR-200
3	SEC(kWh/(m ² .a))	Cold region:-79.3
		Average region:-41.5
4	Declared typology	RVU,BVU
5	Type of drive	Multi-speed
6	Type of HRS	Recuperative
7	Thermal efficiency(%)	81
8	Maximum flow rate(m ³ /h)	200
9	Electric power input(kW)	71
10	Casing sound power level(dB)	45
11	Reference flow rate(m ³ /h)	0.045
12	Reference pressure difference(Pa)	52
13	SPI(W/(m ³ /h))	0.23
14	Control factor and typology	Local demand control
15	Maximum leakage rate(%)	10 Or less
16	Mixing rate of non-ducted	-
17	Visual filter warning	Refer to instruction book
18	Instructions to install regulated supply/ exhaust grilles for unidirectional ventilation	-
19	Internet address for disassembly instructions	https://sinclair-solutions.com
20	Airflow sensitivity for non-ducted units	-
21	Air tightness for non-ducted units	-
22	AEC(kWh/a)	Average region 1.7
23	AHS(kWh primary energy/a)	Average 45.2,Cold 88.4,Warm 20.4

Table 9-4 Required information for NRVU in COMMISSION REGULATION (EU) No.1253/2014 ANNEX V

No.	Information Item	Comment							
1	Supplier's name	Sinclair							
2	Model name	SHR-300	SHR-400	SHR-500	SHR-800	SHR-1000	SHR-1500	SHR-2000	
3	Declared typology	NRVU,BVU	NRVU,BVU	NRVU,BVU	NRVU,BVU	NRVU,BVU	NRVU,BVU	NRVU,BVU	
4	Type of drive	Multi-speed	Multi-speed	Multi-speed	Multi-speed	Multi-speed	Multi-speed	Multi-speed	
5	Type of HRS	Other	Other	Other	Other	Other	Other	Other	
6	Thermal efficiency(%)	75.5	77.7	80.6	78.7	82.8	75.5	77.2	
7	Nominal flow rate(m ³ /s)	0.083	0.111	0.139	0.222	0.278	0.417	0.556	
8	Electric power input(kW)	0.098	0.115	0.157	0.324	0.383	0.677	0.956	
9	SFPint(W/(m ³ /h))	619	636	682	792	785	702	730	
10	Face velocity(m/s)	0.67	0.63	0.66	0.87	0.87	1.0	1.0	
11	Nominal external pressure(Pa)	93	100	96	146	160	180	200	
12	Internal pressure drop(Pa)	179	218	189	357	384	253	322	
13	Internal pressure drop of non-ventilation components(Pa)	-	-	-	-	-	-	-	
14	Efficiency in Regulation (EU) NO 327/2011	Out of scope	Out of scope	Out of scope	33	33	49.7	49.7	
15	Maximum leakage rate(%)	10 Or less	10 Or less	10 Or less	10 Or less	10 Or less	10 Or less	10 Or less	
16	Energy classification of the filters	-	-	-	-	-	-	-	
17	Visual filter warning	Refer to instruction book							
18	Casing sound power level(dB)	48	48	50	55	54	69	70	
19	Internet address for disassembly instructions	https://sinclair-solutions.com							

NOTE CONCERNING PROTECTION OF ENVIRONMENT

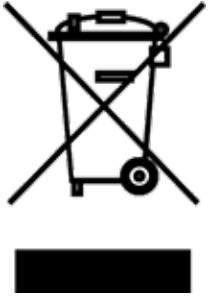

This product must not be disposed of via normal household waste after its service life, but must be taken to a collection station for the recycling of electrical and electronic devices. The symbol on the product, the operating instructions or the packaging indicate such disposal procedures. The materials are recyclable in accordance with their respective symbols. By means of re-use, material recycling or any other form of recycling old appliances you are making an important contribution to the protection of our environment. Please ask your local council where your nearest disposal station is located.

PRODUCER

SINCLAIR CORPORATION Ltd.
16 Great Queen Street
WC2B 5AH London
United Kingdom
www.sinclair-world.com

This product was manufactured in China (Made in China).

REPRESENTATIVE

SINCLAIR Global Group s.r.o.
Purkynova 45
612 00 Brno
Czech Republic

TECHNICAL SUPPORT

SINCLAIR Global Group s.r.o.
Purkynova 45
612 00 Brno
Czech Republic
Tel.: +420 800 100 285 | Fax: +420 541 590 124
www.sinclair-solutions.com | info@sinclair-solutions.com

