



**FULL DC INVERTER SYSTEMS
ENGINEERING DATA BOOK**

AHU KIT AHUKZ-xxD

COMMERCIAL AIR CONDITIONERS SDV5

Original instructions

IMPORTANT NOTE:

Read this manual carefully before installing or operating your new air conditioning unit. Make sure to save this manual for future reference.

CONTENTS

1 Introduction	3
2 System Layout	4
3 VRF-AHU System Schematic	5
4 Nomenclature	6
5 Typical Applications	6
6 Specifications	8
7 Match table.....	8
8 Combination table.....	9
9 Dimensions	10
10 Piping Diagrams	11
11 General Notes	12
12 Installation of DX AHU Control Box.....	13
13 Selection of Controllers	44
14 Dip Switch definitions	52
15 Error Code and Query.....	58
16 Accessories.....	60
17 Appendix.....	61

1 Introduction

The AHU control box can be connected to the heat pump/heat recovery/cooling only ODU and the third party AHU. Every third party AHU can be connected to one AHU control box or to several AHU control boxes in a parallel connection (up to four). This manual describes how to install and operate an AHU control box.

Using an AHU control box, a unit can be controlled by either return air temperature or by outlet air temperature.

- When return air temperature control is selected, the connected AHU can be considered to be a standard IDU.
- Users can opt to use the factory controller or a third party controller.
- The AHU control box has an input port of 0-10V. A third party controller is required to provide 0-10V of input. The system capacity requirement or temperature can be set based on 0-10V input.
- **Appearance of the AHU Control Box:**

No	Parts
1	Electric control Box Cover Assembly
2	E- part box assembly
3	Electronic Expansion Valve Assembly
4	Electric Control Box Welding Assembly
5	Clip
6	Cable Gland
7	Rubber Ring
8	Fixing board, pipes

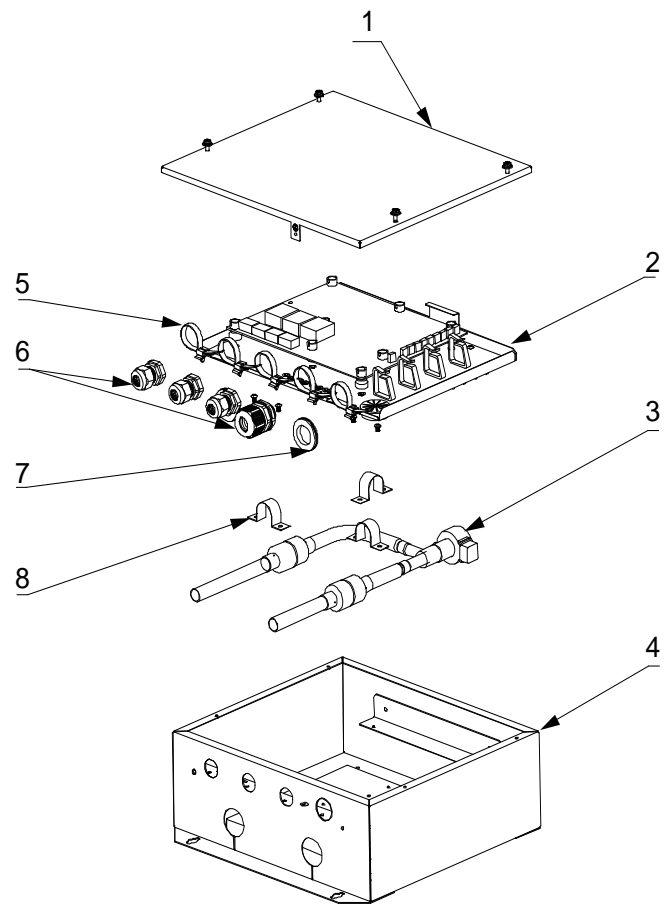

2 System Layout

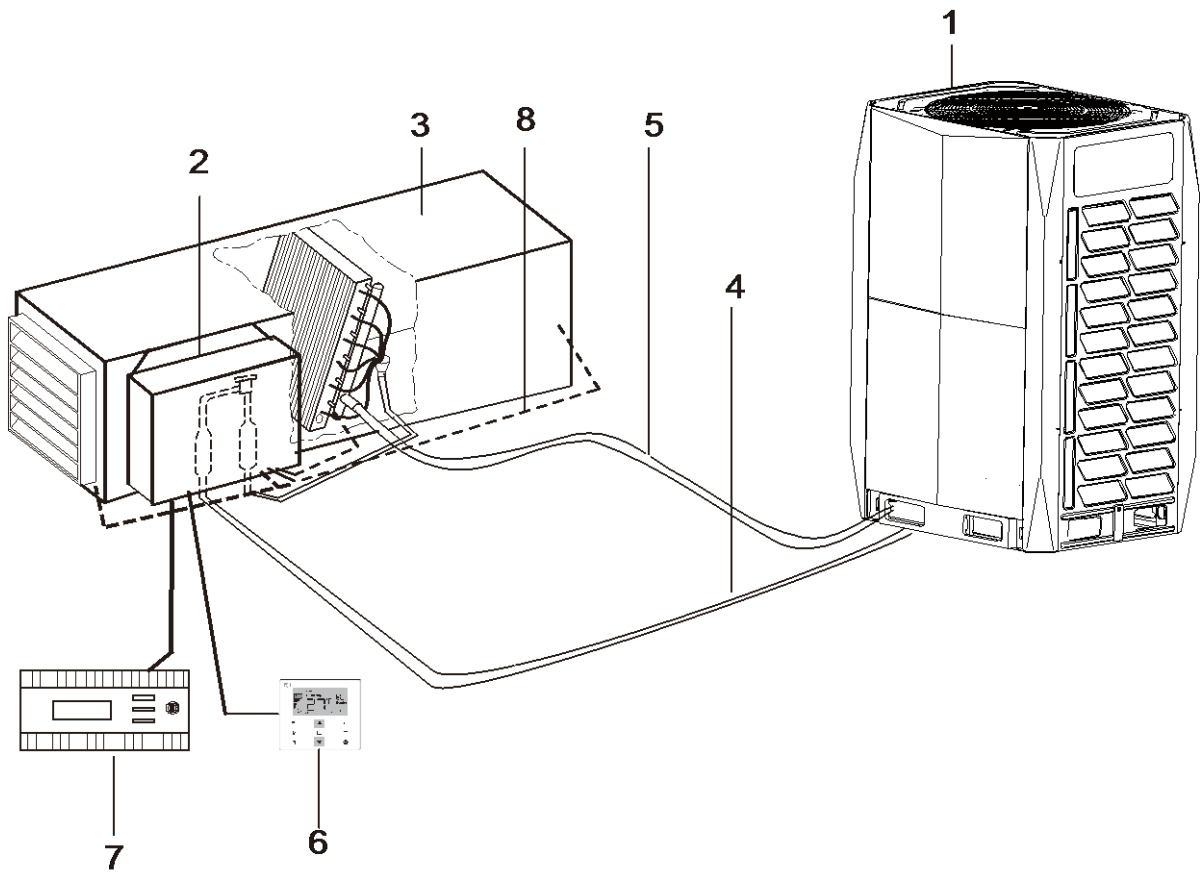

No.	Name	Description
1	ODU	Outdoor unit
2	AHU control box	-
3	Air handling unit (AHU)	Field supply
4	Liquid pipe	Field supply
5	Gas pipe	Field supply
6	Wired controller	Factory controller
7	Third party controller	Field supply
8	Temperature sensor wiring	-

3 VRF-AHU System Schematic

Figure 1-1.1: System schematic

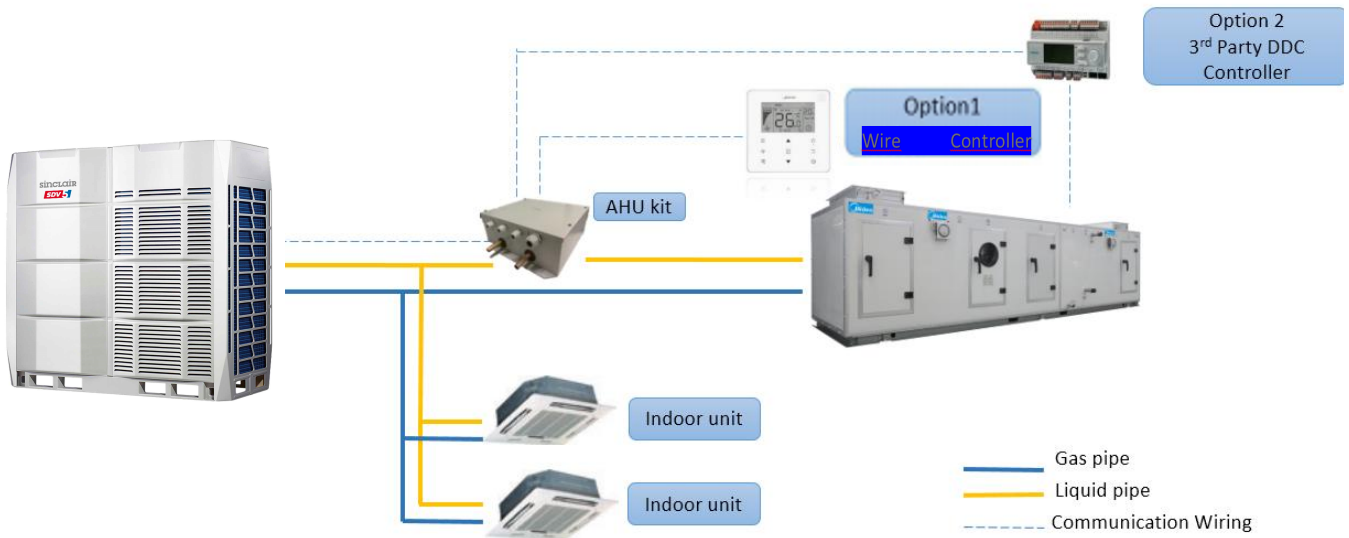

The system is composed by largely indoor and outdoor parts. Outdoor part is Sinclair VRF outdoor unit. Indoor part includes other brand direct expansion type AHU (Local supply) or Sinclair brand direct expansion type AHU and Sinclair AHU control box. AHU control box forms the connection between Sinclair VRF outdoor unit and other brand direct expansion type AHU.

1. Outdoor: Sinclair VRF outdoor unit
Small SDV4, SDV4, SDV4F, SDV5, SDV5-3P
2. Indoor: Direct expansion type AHU (Local supply)
Direct Expansion type AHU supplied by local market
3. AHU Control Box

PCBs, EXV, EXV Coil, Temperature sensors (Coil in/out temperature, coil temperature, ambient temperature), Wired controller and Display board.

4.DDC (Direct Digital Control) controller

DDC controller is optional. It's supplied by the third party such as SIEMENS. Through DDC, some functions such as temperature setting control and capacity setting control can be realized.

Product Lineup

Model	Appearance
AHUKZ-00D	
AHUKZ-01D	
AHUKZ-02D	
AHUKZ-03D	

4 Nomenclature

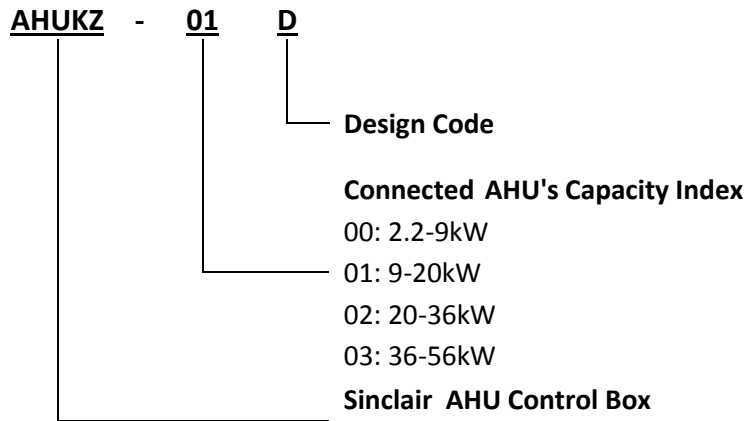

5 Typical Applications

5.1 Single VRF DX AHU Control Box connects to one AHU

When the DX type AHU's capacity is less than 56kW, single DX VRF AHU control box connects to one AHU, method is suggested as below.

Figure 1-4.1: Single VRF DX AHU Control Box connect to one AHU

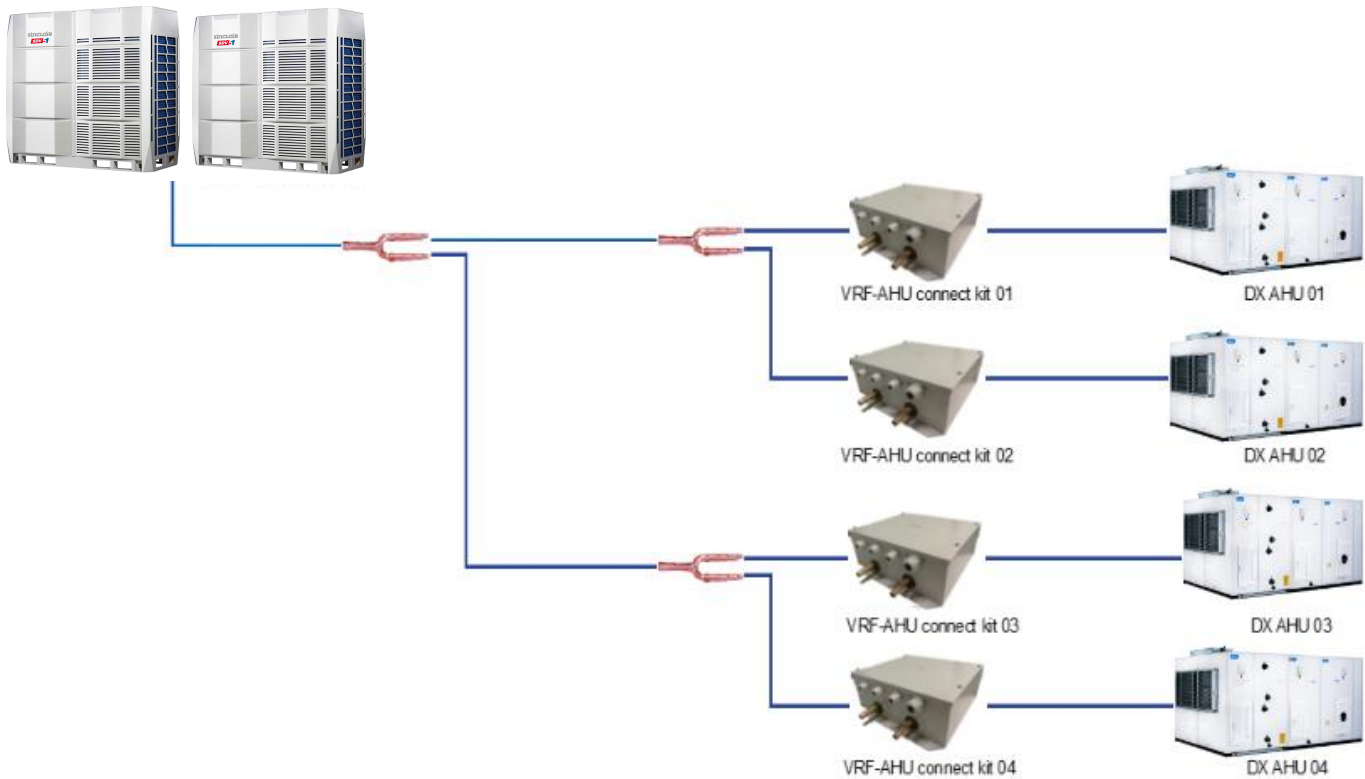

Notes: The example is just for application illustration.

5.2 Multiple DX VRF AHU Control Boxes connect with one AHU

When the DX type AHU's capacity is large than 56kW, multiple VRF- AHU control boxes connect to one AHU, method is suggested. Maximum 4 VRF- AHU control boxes can be combined to connect large capacity AHU.

Figure 1-4.2: Multiple VRF DX AHU Control Boxes connect to one AHU

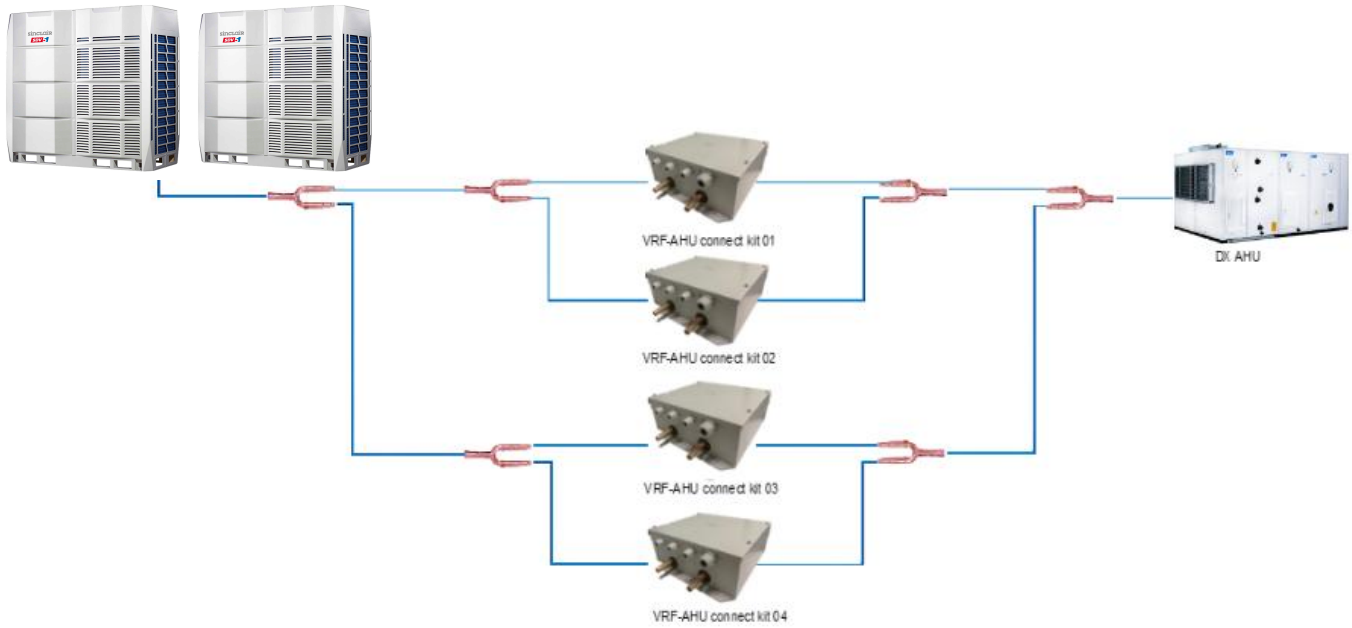

Notes: The example is just for application illustration.

5.3 AHU and VRF IDU Combination

DX type AHU and VRF indoor units can be combined in the same refrigerant system.

Figure 1-4.3: AHU and VRF IDU combination application

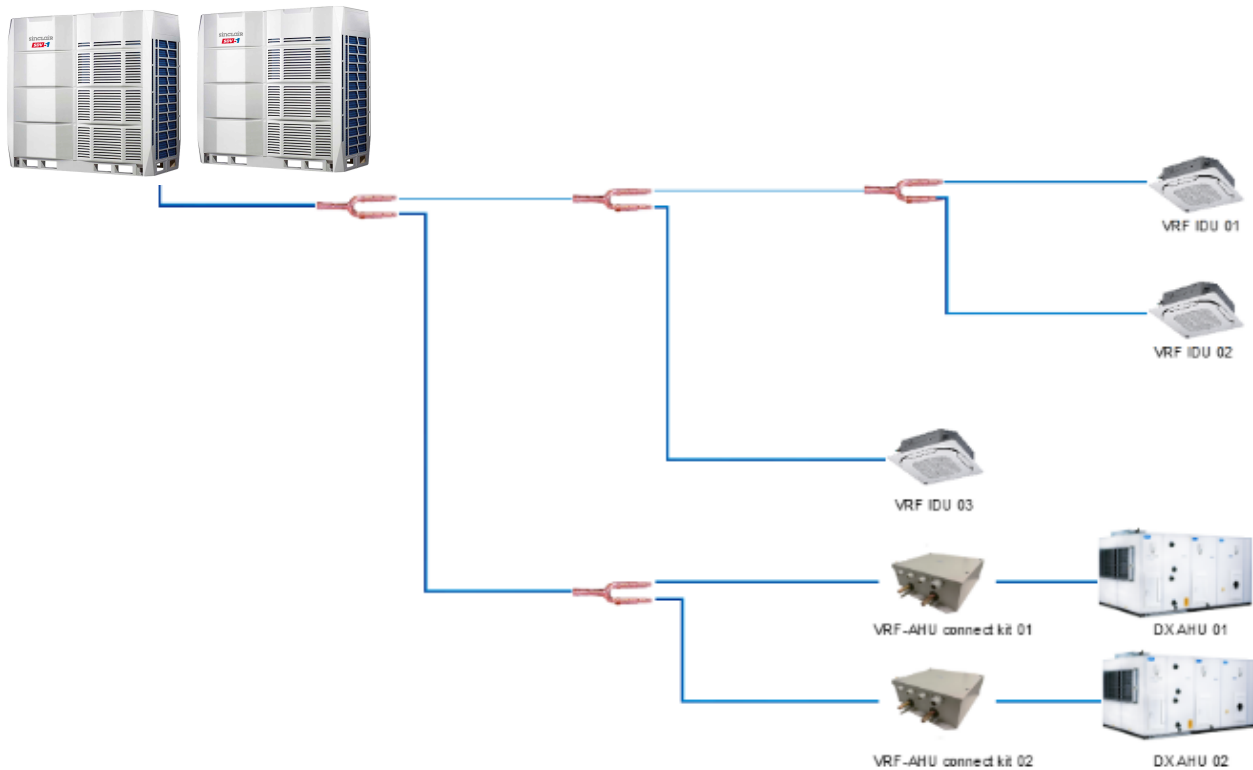

Notes: The example is just for application illustration.

6 Specifications

AHUKZ-00D / AHUKZ-01D / AHUKZ-02D / AHUKZ-03D

Table 2-1.2: AHUKZ-00(01,02,03)D specifications¹

Model		AHUKZ-00D	AHUKZ-01D	AHUKZ-02D	AHUKZ-03D
Power supply		220-240V~ 50/60HZ			
Connected indoor unit	kW	2.2-8	9~20	21~36	37~56
IP-class		IP20	IP20	IP20	IP20
Piping size (in/out)	mm	Φ8/Φ8	Φ8/Φ8	Φ12.7/Φ12.7	Φ15.9/Φ15.9
Weight (Net/Gross)	kg	5.6/8.6	5.6/8.6	5.9/8.8	6.0/8.9
Dimension	mm	393/341/125			
Packing dimension	mm	490*440*205			

7 Match table

Model	Setting cooling capacity (HP)	AHU capacity(kw)	Internal Volume of Heat Exchanger(dm ³)	Reference air volume (m ³ /h)	Max air Volume (m ³ /h)
AHUKZ-00D	0.8	1.8-2.8	0.35~0.4	500	600
	1	2.8~3.6	0.4~0.45	550	650
	1.2	3.6~4.5	0.45~0.55	600	750
	1.7	4.5~5.6	0.55~0.65	750	900
	2	5.6~7.1	0.65~0.75	850	1000
	2.5	7.1~8	0.75~1.2	1000	1300
	3	8~9	1.20~1.66	1300	1800
AHUKZ-01D	3.2	9~11.2	1.66~2.06	1400	2400
	4	11.2~14	2.06~2.58	1700	3000
	5	14~18	2.58~3.32	2100	3800
	6	18~20	3.32~3.69	2700	4300
AHUKZ-02D	8	20~25	3.69~4.61	3000	5400
	10	25~30	4.61~5.53	3700	6400
	12	30~36	5.53~6.64	4500	7700
AHUKZ-03D	14	36~40	6.64~7.37	5400	8600
	16	40~45	7.37~8.29	6000	9700
	18	45~50	8.29~9.21	6700	10800
	20	50~56	9.21~10.32	7500	12000

8 Combination table

	AHU capacity (kW)	Internal volume of heat exchanger (dm ³)	Reference air volume (m ³ /h)	Max air volume (m ³ /h)
AHUKZ-02D+AHUKZ-02D	56~65	9.63~11.56	8200	14000
AHUKZ-02D+AHUKZ-03D	65~70	11.03~12.54	9400	15100
AHUKZ-02D+AHUKZ-03D	70~76	11.90~13.30	10200	16400
AHUKZ-02D+AHUKZ-03D	76~80	12.62~14.01	10800	17200
AHUKZ-02D+AHUKZ-03D	80~90	13.40~15.26	11800	19400
AHUKZ-03D+AHUKZ-03D	90~100	15.26~17.80	13400	21600
AHUKZ-03D+AHUKZ-03D	100~112	17.51~19.61	15000	24100
AHUKZ-02D+AHUKZ-02D+AHUKZ-03D	112~125	18.85~21.36	16700	27000
AHUKZ-02D+AHUKZ-03D+AHUKZ-03D	125~140	21.19~24.07	18700	30200
AHUKZ-03D+AHUKZ-03D+AHUKZ-03D	140~155	23.74~26.62	21000	33400
AHUKZ-02D+AHUKZ-02D+AHUKZ-03D+AHUKZ-03D	155~175	26.20~29.36	23700	37800
AHUKZ-02D+AHUKZ-03D+AHUKZ-03D+AHUKZ-03D	175~198	29.02~32.84	26200	42700
AHUKZ-03D+AHUKZ-03D+AHUKZ-03D+AHUKZ-03D	198~225	33.17~37.15	30000	48600

9 Dimensions

AHUKZ-00D / AHUKZ-01D / AHUKZ-02D / AHUKZ-03D

Figure 2-4.1: AHUKZ-00(01,02,03)D dimensions (unit: mm)

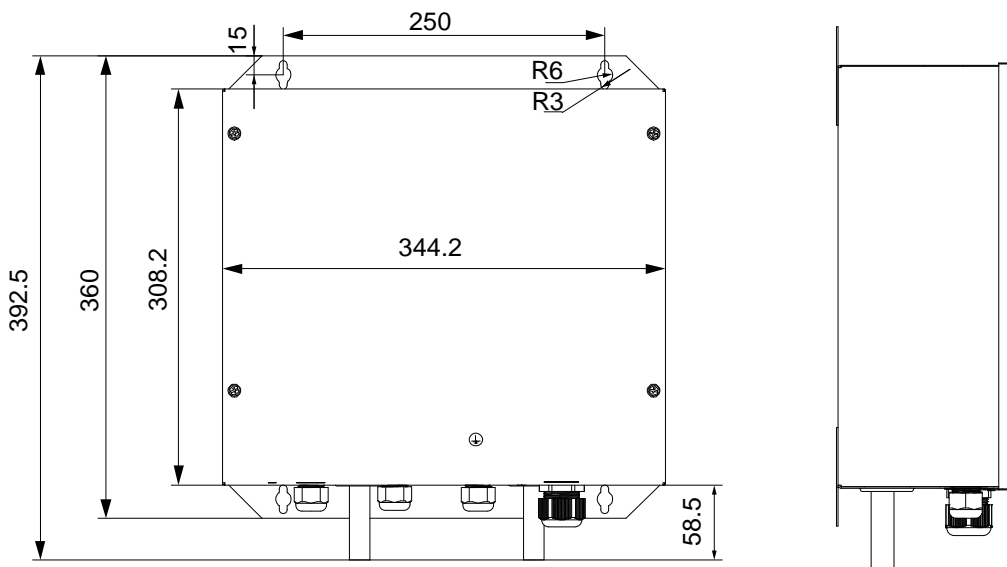
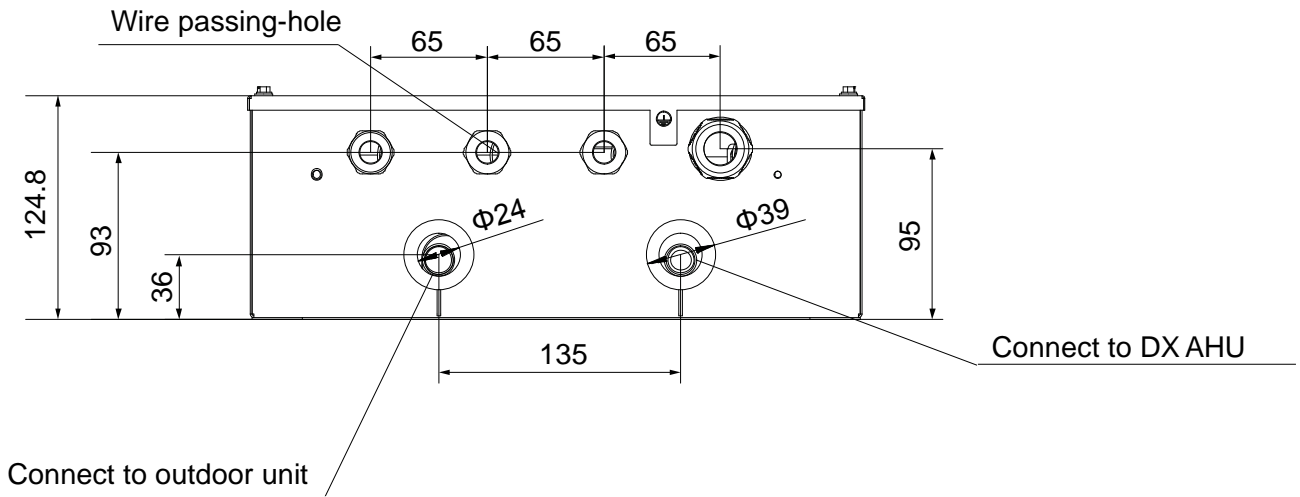

10 Piping Diagrams

AHUKZ-00D / AHUKZ-01D / AHUKZ-02D/AHUKZ-03D

Figure 2-5.1: Piping diagrams

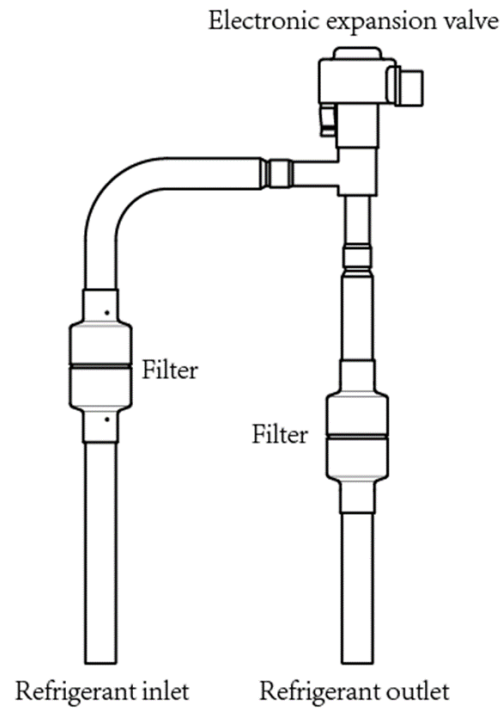

11 General Notes

11.1 Notes for Installers

The information contained in this Engineering Data Book may primarily be of use during the system design stage of a VRF-AHU project. Additional important information which may primarily be of use during field installation has been placed in boxes, such as the example below, titled “Notes for installers”.

Notes for installers



- Notes for installers boxes contain important information which may primarily be of use during field installation, rather than during desk-based system design.

11.2 Definitions

In this Engineering Data Book, the term “applicable legislation” refers to all national, local and other laws, standards, codes, rules, regulations and other legislation that apply in a given situation.

11.3 Precautions

All system installation including electrical works must only be carried out by competent and suitably qualified, certified and accredited professionals and in accordance with all applicable legislation.

12 Installation of DX AHU Control Box

12.1 Pre- Installation

For ODU installation, please refer to the ODU installation manual. For AHU installation, please refer to the AHU installation manual. For charging and adding refrigerant, please refer to both manuals.

This control box can only connect to an R410A refrigerant system.

During the installation of connecting pipes, do not let air, dust, or other sundries enter the piping system.

Install the connecting pipe only after the AHU control box and ODUs have been fixed.

When installing the connecting pipes, it must be kept dry and do not let water enter the piping system.

Notes for installers



- When units are delivered check whether any damage occurred during shipment. If there is damage, submit a written report to the shipping company.
- Check that the model, specifications and quantity of the units delivered are as ordered.
- Check that all accessories ordered have been included. Retain the Owner's Manual for future reference.

12.2 VRF DX AHU Control Box Installation

VRF DX AHU Control box's installation should take account of the following considerations:

- VRF DX AHU Control Boxes should be vertical installed.
- Please use ST3.9x25 screws for installation.
- VRF DX AHU Control boxes can't be installed horizontally.
- Make sure the laying direction of the refrigerant pipe and the connecting place of the connecting wire.

12.3 Selecting ODUs and Match restrictions

1. An AHU control box can be connected with heat pump VRF, heat recovery VRF as well as cooling only VRF.
2. **VRF DX AHU Control Box + Heat Recovery ODU:**
 - a) **Heat Recovery ODU + AHU (Using Return Air):** Not allowed
 - b) **Heat Recovery ODU + AHU (Using Return Air) + Normal indoor units:**
 - The combination ratio of the system should be 50-100%
 - The ratio of AHU should be less than 50% of the total capacity of outdoor units.
 - c) **Heat Recovery ODU + VRF DX AHU Control Box + AHU (Using Fresh Air):** Not Allowed
 - d) **Heat Recovery ODU + VRF DX AHU Control Box + AHU (Using Fresh Air) + Normal indoor units:**
 - The combination ratio of the whole system should be 50-100%
 - The Fresh Air AHU can only be controlled by the outlet air temperature.
 - The Fresh Air AHU capacity should not exceed 30% of the ODU capacity

3. VRF DX AHU Control Box + Heat Pump/ Cooling Only ODU:

- a) **Heat Pump/Cooling Only ODU + AHU (Using Return Air) only Combination: Allowed**
 - The combination ratio of the system should be 50-100%
- b) **Heat Pump/Cooling Only ODU + AHU (Using Return Air) + Normal indoor units:**
 - The combination ratio of the system should be 50-100%
 - The AHU capacity should not exceed 50% of the ODU capacity.
- c) **Heat Pump/ Cooling Only ODU +VRF DX AHU Control Box + AHU (Using Fresh Air):**
 - The combination ratio of the system should be 50-100%.
 - The Fresh Air AHU can only be controlled by the outlet air temperature.
- d) **Heat Pump/ Cooling Only ODU +VRF DX AHU Control Box + AHU (Using Fresh Air) + Normal indoor units:**
 - The combination ratio of the system should be 50-100%
 - The Fresh Air AHU can only be controlled by the outlet air temperature.
 - The Fresh Air AHU capacity should not exceed 30% of the ODU capacity

Notes: For Mini VRF ODU, only return air temperature control can be selected (outlet air temperature control cannot be selected).

12.4 Selecting an AHU Control Box that matches AHU

The following parameters and restrictions stipulated in Table 3-3 must be considered when selecting the AHU control box. Otherwise, it may adversely affect the ODU's service life, operating range and reliability.

Notes for installers



If the total capacity of IDUs exceeds the rated capacity of the ODU, the cooling and heating performance may be reduced when IDUs are in operation

Model	Setting cooling capacity (HP)	AHU capacity(kw)	Internal Volume of Heat Exchanger(dm ³)	Reference air volume (m ³ /h)	Max air Volume (m ³ /h)
AHUKZ-00D	0.8	1.8-2.8	0.35~0.4	500	600
	1	2.8~3.6	0.4~0.45	550	650
	1.2	3.6~4.5	0.45~0.55	600	750
	1.7	4.5~5.6	0.55~0.65	750	900
	2	5.6~7.1	0.65~0.75	850	1000
	2.5	7.1~8	0.85~0.95	1000	1300
	3	8~9	1.20~1.60	1300	1800
AHUKZ-01D	3.2	9~11.2	1.66~2.06	1400	2400
	4	11.2~14	2.06~2.58	1700	3000
	5	14~18	2.58~3.32	2100	3800
	6	18~20	3.32~3.69	2700	4300
AHUKZ-02D	8	20~25	3.69~4.61	3000	5400
	10	25~30	4.61~5.53	3700	6400
	12	30~36	5.53~6.64	4500	7700
AHUKZ-03D	14	36~40	6.64~7.37	5400	8600
	16	40~45	7.37~8.29	6000	9700
	18	45~50	8.29~9.21	6700	10800
	20	50~56	9.21~10.32	7500	12000

Note: The evaporation temperature (cooling) is 6° C, the ambient temperature is 27° C DB/19° C WB, and the superheat degree is 5° C

When the capacity of AHU exceeds 56 kW, up to four AHU control boxes can be connected in parallel to one AHU. See Table for recommended parallel connection methods.

	AHU capacity (kW)	Internal volume of heat exchanger (dm³)	Reference air volume (m³/h)	Max air volume (m³/h)
AHUKZ-02D+AHUKZ-02D	56~65	9.63~11.56	8200	14000
AHUKZ-02D+AHUKZ-03D	65~70	11.03~12.54	9400	15100
AHUKZ-02D+AHUKZ-03D	70~76	11.90~13.30	10200	16400
AHUKZ-02D+AHUKZ-03D	76~80	12.62~14.01	10800	17200
AHUKZ-02D+AHUKZ-03D	80~90	13.40~15.26	11800	19400
AHUKZ-03D+AHUKZ-03D	90~100	15.26~17.80	13400	21600
AHUKZ-03D+AHUKZ-03D	100~112	17.51~19.61	15000	24100
AHUKZ-02D+AHUKZ-02D+AHUKZ-03D	112~125	18.85~21.36	16700	27000
AHUKZ-02D+AHUKZ-03D+AHUKZ-03D	125~140	21.19~24.07	18700	30200
AHUKZ-03D+AHUKZ-03D+AHUKZ-03D	140~155	23.74~26.62	21000	33400
AHUKZ-02D+AHUKZ-02D+AHUKZ-03D+AHUKZ-03D	155~175	26.20~29.36	23700	37800
AHUKZ-02D+AHUKZ-03D+AHUKZ-03D+AHUKZ-03D	175~198	29.02~32.84	26200	42700
AHUKZ-03D+AHUKZ-03D+AHUKZ-03D+AHUKZ-03D	198~225	33.17~37.15	30000	48600

Perform checks upon completion of installation and pay extra attention to the following items:

- Whether the temperature sensor is properly installed
- Whether AHU control boxes are properly secured
- Whether electrical connections meet specifications
- Whether wires and pipes are correctly connected
- Whether AHU control boxes are properly grounded
- Whether capacity DIP switches are properly set

12.5 Choosing an Installation Site

The following conditions must be met:

- If the AHU control box is installed outdoors, take waterproofing measures to protect it from rainwater.
- Avoid direct sunlight as it will heat the AHU control box and shorten its service life, hence affecting operation.
- Select a level, solid-mounting surface.
- Do not install the AHU control box on or above the surface of the ODU.
- Reserve some space in front of the AHU control box for future maintenance.
- Ambient temperature: -25°C to 52°C

Range for Inlet Air Temperature on AHU Coil

Cooling: 17°C to 43°C

Heating: 5°C to 30°C

IP Protection Degree: IP20 (after proper installation)

12.6 Installation Method and Size

For installation of the AHU, refer to the AHU installation manual.

The AHU control box can be installed in two ways:

1. When the AHU control box's EXV remains with the AHU control box, the AHU control box must be installed vertically as shown in figure.
2. When the AHU control box's EXV is split from the AHU control box, the AHU control box can be installed vertically or horizontally, but the split EXV must be vertical as shown in figure

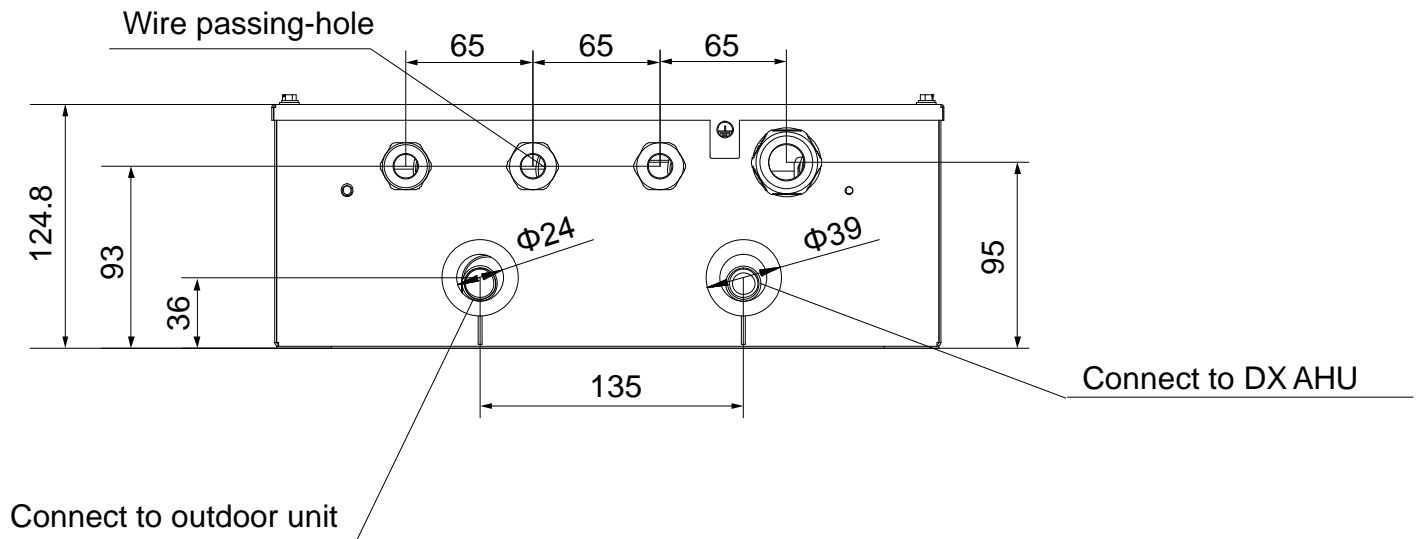

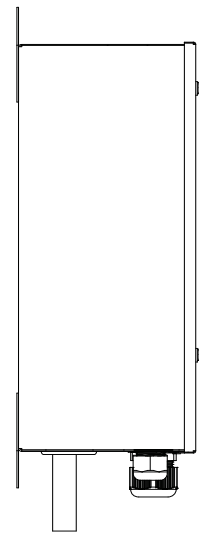
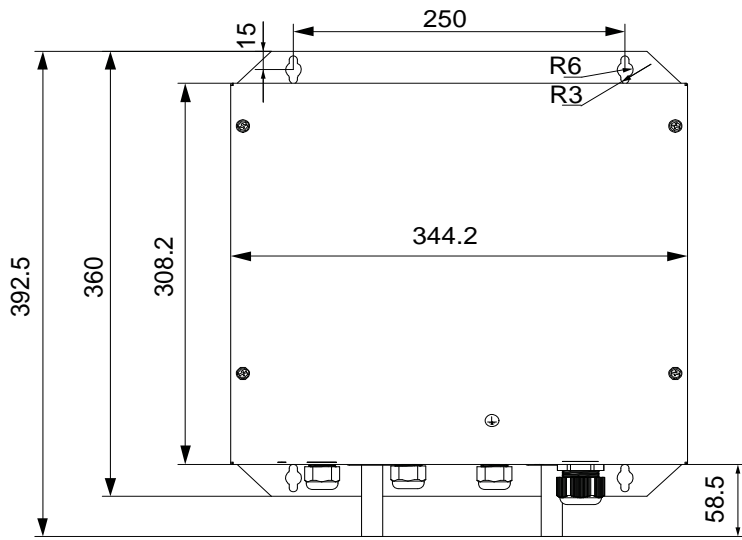

↑
Install vertically

Installation method : Hanging

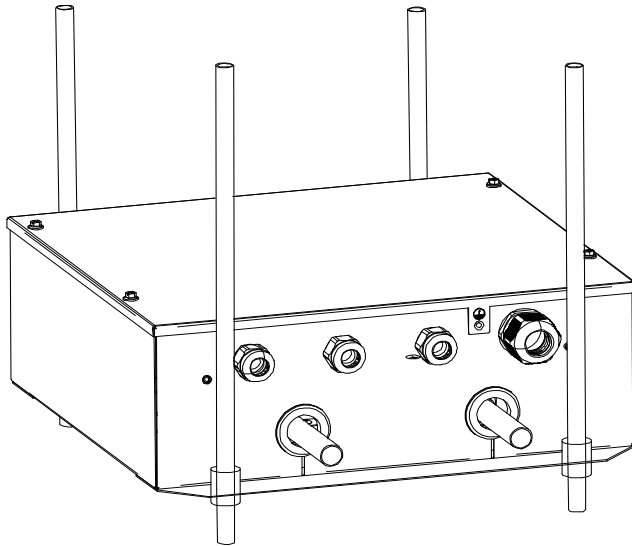

Wrong installation way

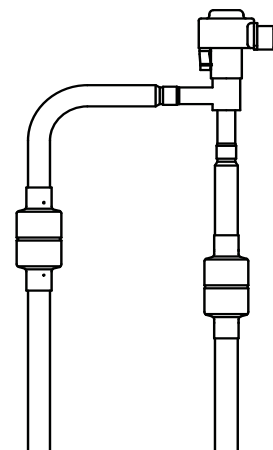
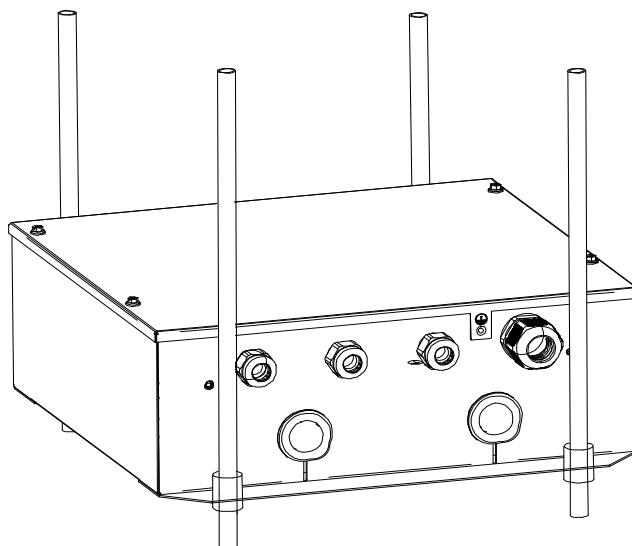

Right installation way

12.7 How to remove EXV from the AHU Control Box

The EXV may be removed from the AHU control box and positioned in an external location. Follow these steps to remove the EXV from the box.

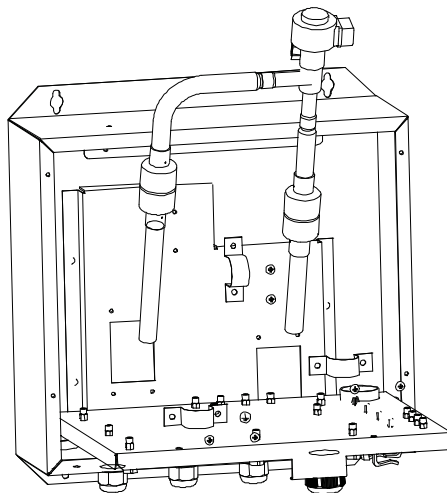
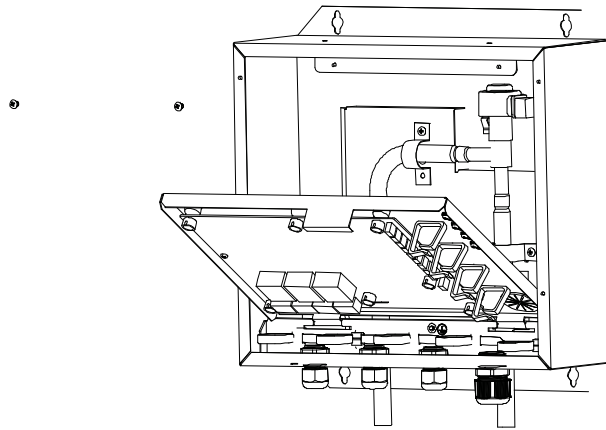
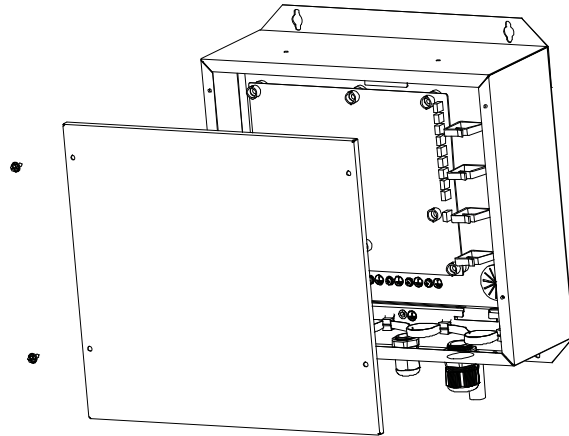

12.8 Refrigerant Piping

12.8.1 Material and Size of piping

Only seamless phosphorus-deoxidized copper piping that complies with all applicable laws should be used. Temper grades and minimum thicknesses for different diameters of piping are specified in Table.

Piping Outer Diameter (mm)	Temper	Min. Thickness (mm)
Φ6.35	O (annealed)	0.8
Φ9.53		0.8
Φ12.7		0.8
Φ15.9		1.0
Φ19.1		1.0
Φ22.2		1/2H (half hard)
Φ25.4	1.2	
Φ28.6	1.3	
Φ31.8	1.5	
Φ38.1	1.5	
Φ41.3	1.5	
Φ44.5	1.5	
Φ54.0	1.8	

Note: O: coiled piping; 1/2H: straight piping.

When the required pipe sizes (in inch) are not available, other diameters (in mm) may also be used, provided that the following is taken into account:

- Select the pipe size nearest to the required size.
- Use suitable adapters for the change-over from inch to mm pipes (field supply)

12.8.2 Pipe Limits

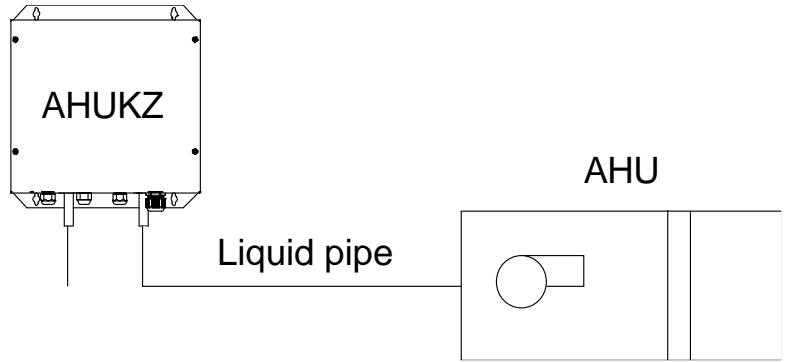

- The connecting distance of each control box and AHU should not be more than 8 m. If the AHU control box and EXV are to be installed apart, the distance between them must be within 5 m.
- The maximum allowed piping length between the ODU and the AHU control box depends on the ODU model.

12.8.3 Welding Precautions

1. Nitrogen must be applied before welding. Failure to apply nitrogen in advance may result in a large amount of oxide residue on the interior surface of the copper tube, which will affect the normal operation of the valve body and compressor and may damage the compressor in serious cases.
2. When performing welding, use the pressure relief damper to keep the nitrogen pressure in the pipe at the range of 0.02-0.03 Mpa (as if the air is blowing gently on the skin).

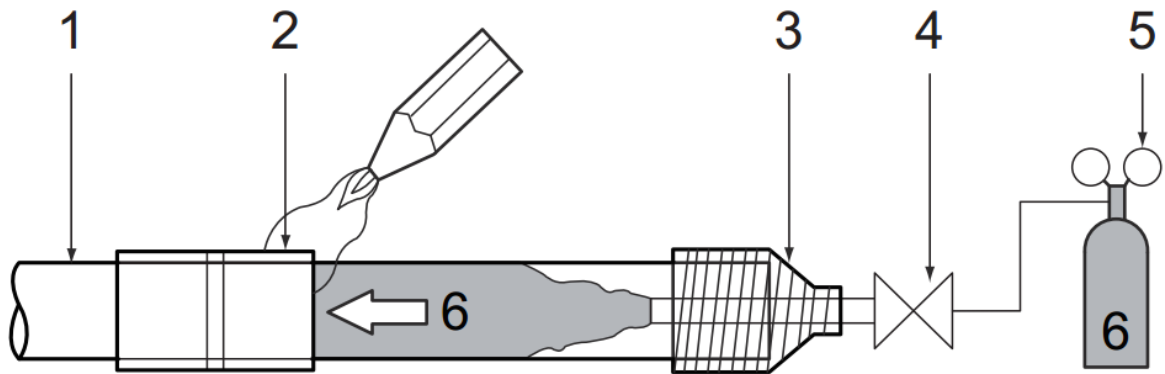

1	Refrigerant piping
2	Part to be brazed
3	Nitrogen connection
4	Hand- Operated valve
5	Pressure relief damper
6	Nitrogen

12.9 AHU Control Box Installation

1. Drill four holes where you want to install the box, with the positions of the holes shown below. Secure the AHU control box using screws.

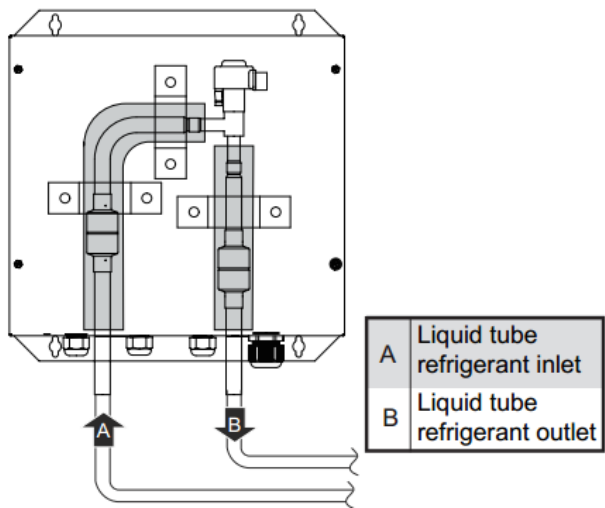

2. Remove seals from the inlet and outlet.
3. Weld pipes on site.

Notes for installers



- When welding pipes at the AHU control box, the valve body and filter should be cooled with a wet cloth to prevent damage to the EXV due to excessively high temperatures.

4. After the pipes are installed, insulate the pipes.
5. Pipe diameter requirements for the AHU control box are as follows:

Control Box Capacity A (×100W)	AHUKZ-00D	AHUKZ-00D	AHUKZ-01D	AHUKZ-02D	AHUKZ-03D
		A<56	56≤A≤90	90<A≤200	200<A≤360
Liquid Side (mm)	φ6.35	φ9.53	φ9.53	φ12.7	φ15.9

For installation of other piping and branch pipes, refer to the ODU installation manual.

12.9.1 Temperature Sensor Installation

There are five temperature sensors (T1, TA, T2A, T2, and T2B) and five extension wires in the accessories, as shown in Figure:

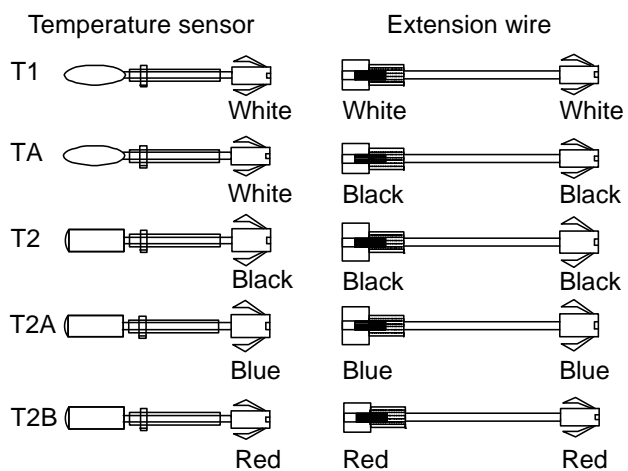

T1, TA

T2A, T2, T2B

Mounting location for temperature sensors:

T1 is an AHU inlet air temperature sensor; it should be installed at the air inlet of the AHU.

T2A is an AHU evaporator inlet temperature sensor; it should be installed at the inlet pipe of the evaporator.

T2 is an AHU evaporator intermediate temperature sensor; it should be installed at the intermediate pipe of the evaporator.

T2B is an AHU evaporator outlet sensor; it should be installed at the outlet pipe of the evaporator.

TA is an outlet air temperature sensor and therefore does not need to be installed if outlet air temperature control is not selected.

Mounting location of T2A, T2, and T2B tube temperature sensors

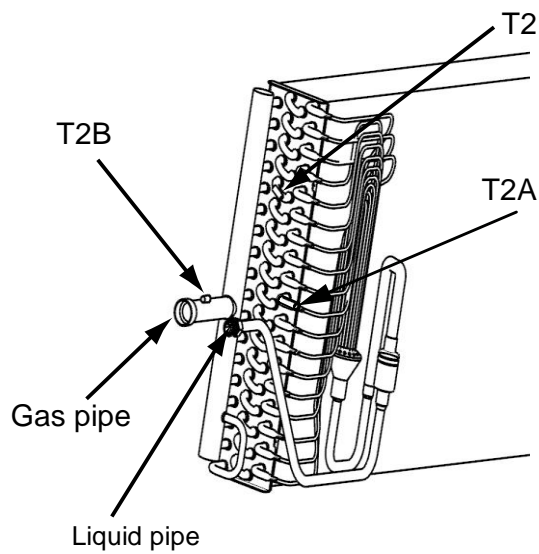

Installation of tube temperature sensors T2A, T2 and T2B:

1. Weld the sIEXVes of the temperature sensors at the designated mounting location.

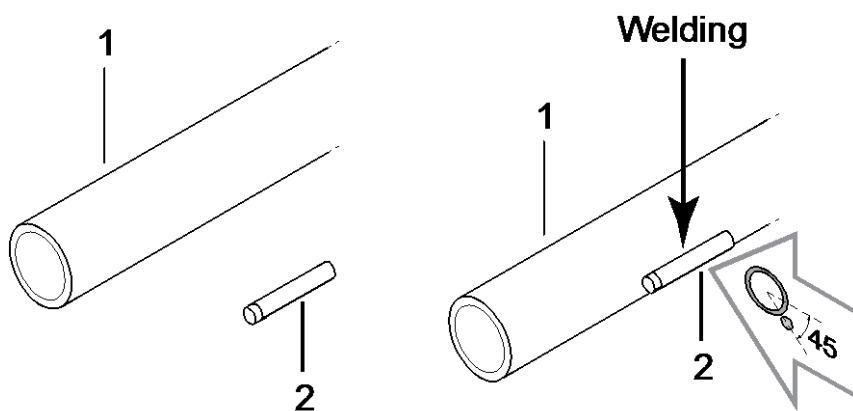

VRF DX AHU Control Box

2. Insert the temperature sensor into the siEXVe after inserting the buckle.

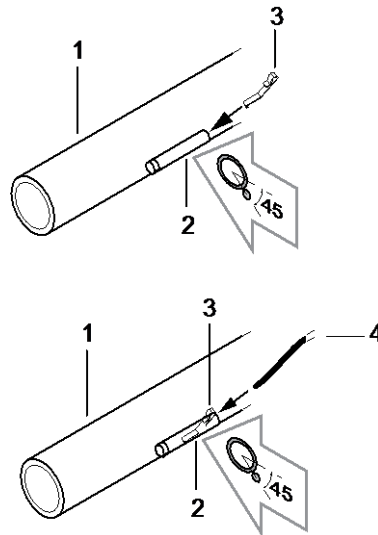

3. Apply insulation materials and secure with cable ties.

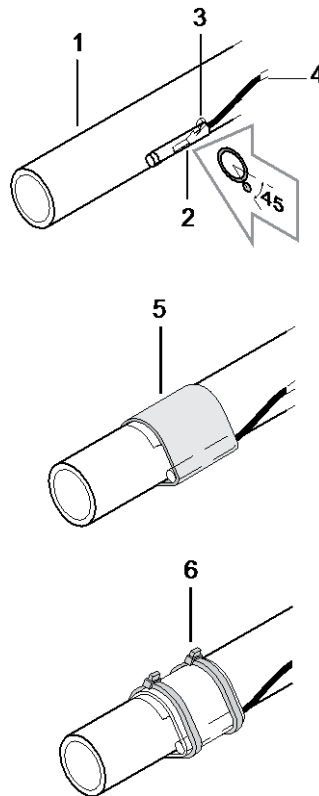

Mounting location of indoor temperature sensors T1 and TA

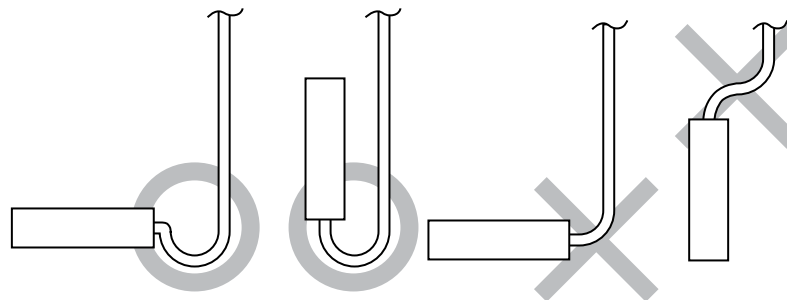
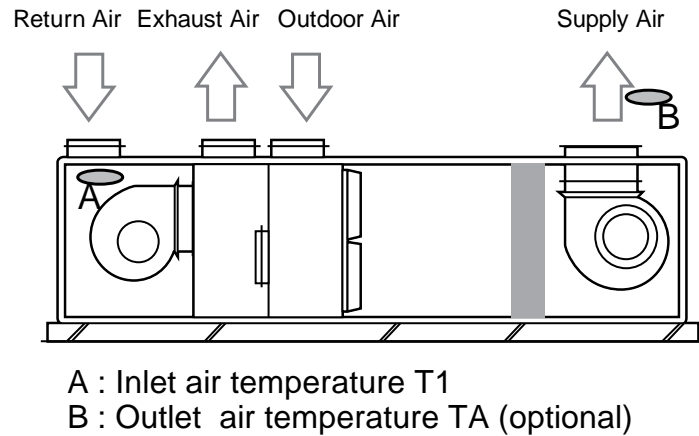

Using an extension cord with the temperature sensor to allow long distance connection

The attached extension cord of the temperature sensor is 9 m long. If an extension cord is required, connect one end of the cord to the AHU control box and the other end to temperature sensor mounted on the AHU.

12.10 Electrical Connection

Notes for installers



- The ODU and AHU control box should use separate power supplies with rated voltage. However, the AHU control box and other AHUs in the same system should use the same power.
- The external power supply to the air conditioner should have ground wiring, which is linked to the ground wiring of the AHU control box and ODU.
- The wiring work should be completed by qualified persons according to circuit drawing.
- The fixed connecting lines must be equipped with at least 3 mm of electric shock spacing.
- A leakage protector should be installed in accordance with the local electrical standard.
- Be sure to properly locate the power wiring and the signal wirings to avoid causing cross-disturbance and their contact with the connecting pipe or stop valve body. Generally, do not twist two wirings together unless the joint is well-soldered and covered with insulator tape.
- Do not turn on the power until the electrical wiring have been correctly completed.

12.10.1 Wiring Diagram

AHUKZ-00D / AHUKZ-01D / AHUKZ-02D/AHUKZ-03D

Figure 2-6.1 AHUKZ-(00,01,02,03) D wiring diagram

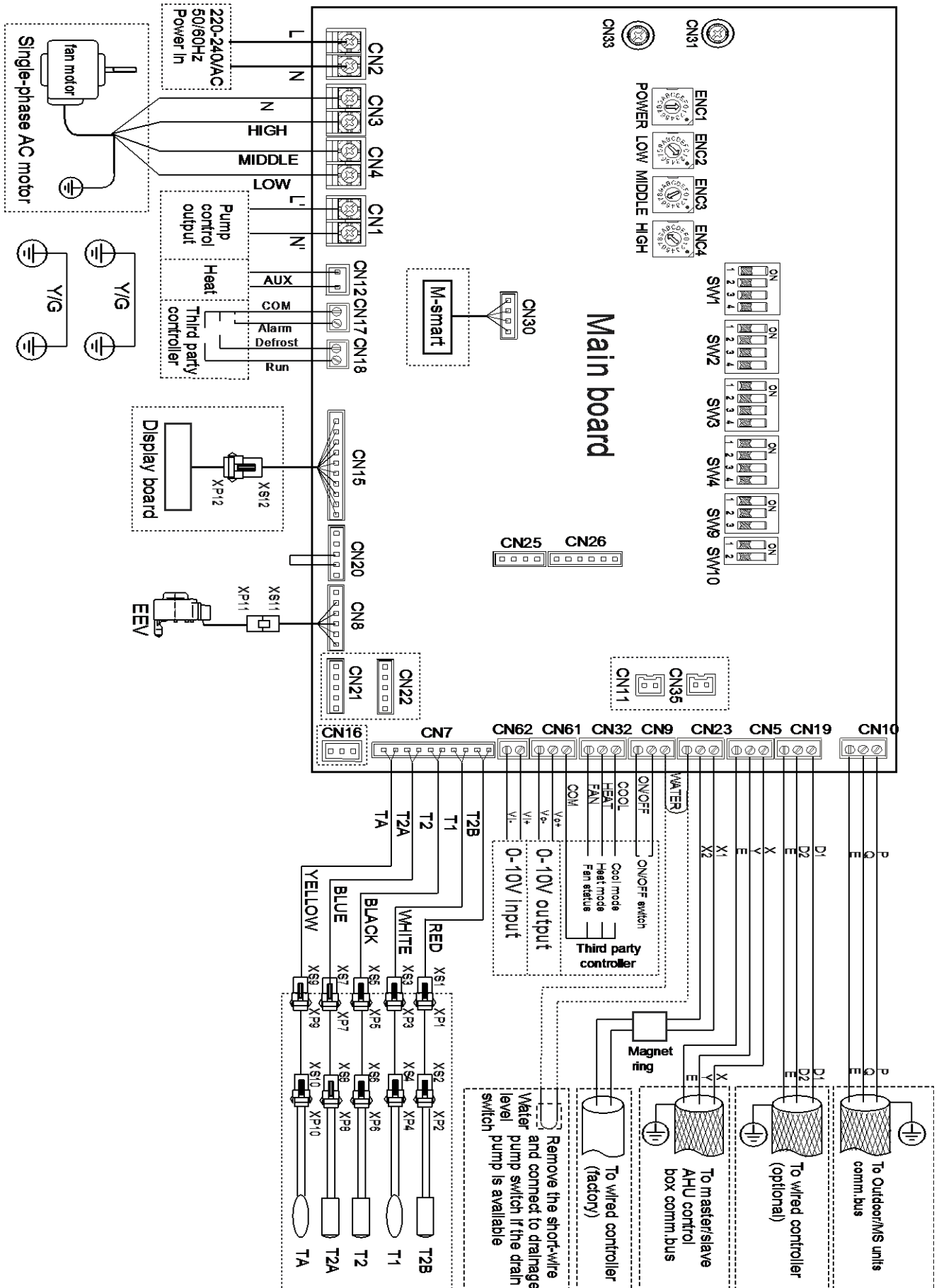

12.10.2 Wiring inside the Electric Control Box

For connections to the DX AHU Control Box: Pull the wires inside through the screw nut and fasten the nut firmly to ensure a good pull relief and water protection.

The cables require an additional pull relief. Strap the cable with the installed tie wrap.

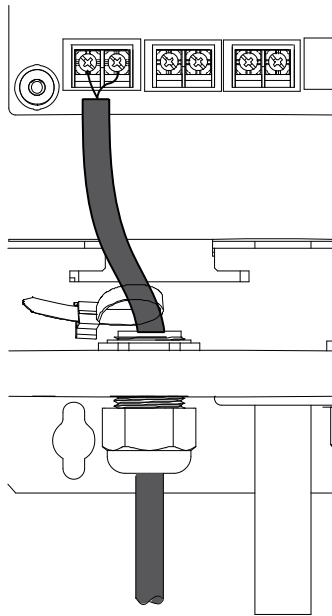

Notes for installers



- The connection with the terminal block must be secure. Failure to do so may result in heating due to poor contact, and even fire in serious cases.
- The power cable and the communication cable should be separated by at least 50 mm to prevent electromagnetic interference.
- Connect the cables to the electric control board in accordance with the circuit diagram shown

Connect the cables to the electric control board in accordance with the circuit diagram shown in Figure:

	Description	Connected To	Cross Section (mm ²)	Maximum Length (m)	Specification
L, N	Power supply	Power supply	*	-	220-240V 1~50/60hz
LOW/MEDIUM/HIGH, N	Fan speed	AHU fan	#	-	220-240V 1~50/60hz
EXV	Electronic expansion valve	Electronic expansion valve	-	5	0-12VDC
T1	Return air temperature	AHU	-	10	0-5VDC
TA	Air outlet temperature	AHU heat exchanger	-	10	0-5VDC
T2A	Heat exchanger inlet temperature	AHU heat exchanger	-	10	0-5VDC
T2	Heat exchanger central temperature	AHU heat exchanger	-	10	0-5VDC
T2B	Heat exchanger outlet temperature	AHU	-	10	0-5VDC
P,Q,E	Communication cable connected to ODU/MS	ODU/MS	0.75	1200	0-5VDC
X1, X2	Wired controller	Factory controller	0.75	200	18VDC
D1, D2,E	Wired controller (optional)	Factory controller	0.75	1200	0-5VDC
X,Y,E	Communicate with AHU Control Box	Master/Slave AHU Control Box	0.75	1200	0-5VDC
ON/OFF	Remote on/off	Third party controller	0.75	**	0-12VDC
cool	Cooling signal	Third party controller	0.75	**	0-12VDC
heat	Heating signal	Third party controller	0.75	**	0-12VDC
fan	Fan status	Third party controller	0.75	**	0-12VDC
alarm	Alarm signal	Third party controller	0.75	**	Dry contact
defrost	Defrosting/anti-cold wind signal	Third party controller	0.75	**	Dry contact
run	Operating Status	Third party controller	0.75	**	Dry contact

Note:* Refer to the cross section of main power cable

Refer to Fan wiring

** The maximum length depends upon the external device that is connected (controller, relay etc.)

12.10.3 Temperature Sensor Wiring

The temperature sensors come with two wiring methods, by dialing DIP switch SW9-2.

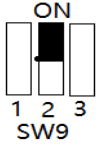
Type	SW9	
1		When SW9-2 is dialed to 0, One or more DX AHU Control Boxes are connected in parallel to one AHU; one coil is connected to multiple control boxes; (hiding faults from the slave unit's temperature sensors: T1, T2, T2A & T2B) (Factory Default)
2		When SW9-2 is dialed to 1, Multiple AHU control boxes are connected in parallel. In the case of multiple coils, one coil is connected to one control box (hiding the errors from slave unit's temperature sensors, T1 & TA)

Type 1: One or more AHU control boxes are connected in parallel to one AHU and the T2A, T2 and T2B sensors of any coil of AHU are connected to the main AHU control box. The T1 or TA sensor is connected to the main board of the main AHU control box.

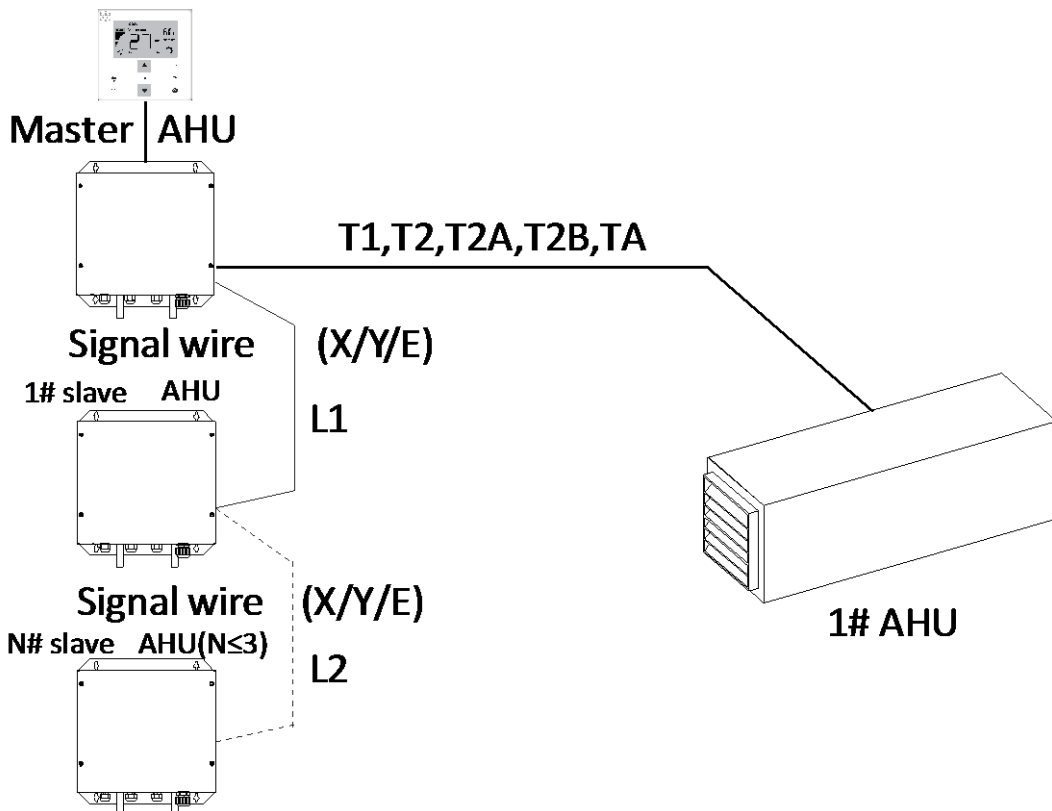

Type 2: Multiple AHU control boxes are connected in parallel. Each coil is connected to an AHU control box. The T2A, T2 and T2B sensors of each coil are connected to the main board of the corresponding AHU control box. The T1 or TA sensor only needs to be connected to the main AHU control box.

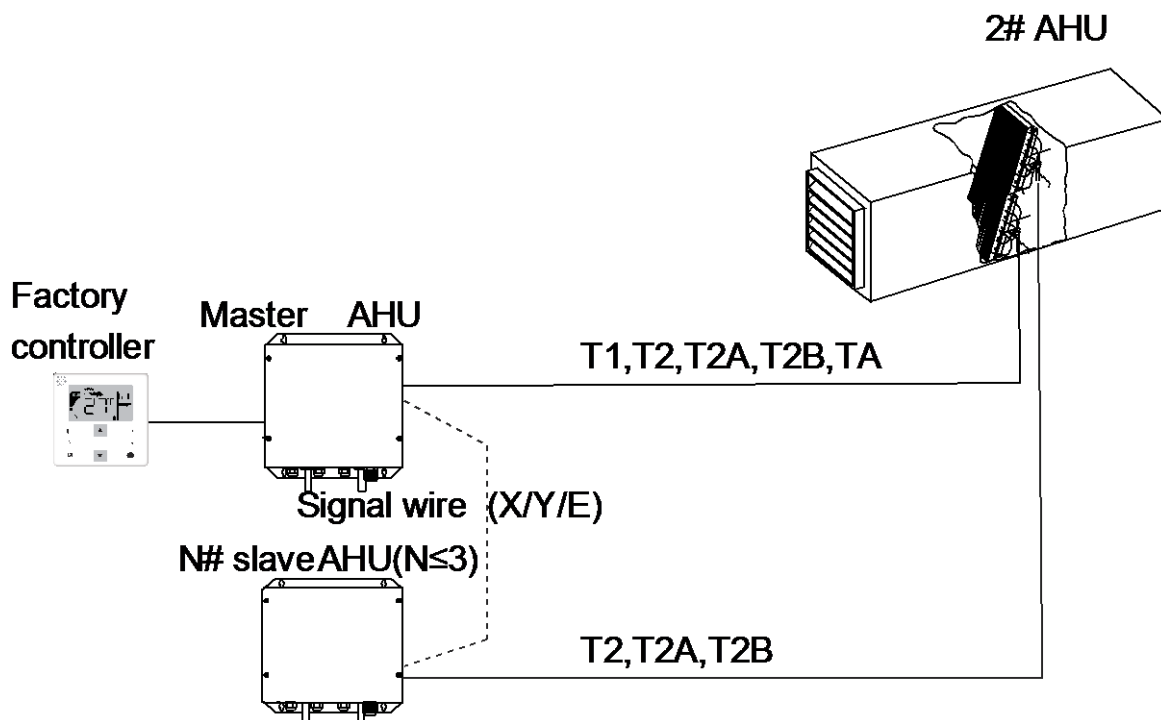

12.10.4 Cross- Section of the Main Power Cable

Please select the main power cables in reference to the tables below:

Model		AHUKZ-00D~01D
Power	Phase	Single-phase
	Voltage and Frequency	220-240V – 50/60Hz
AHU Control Box Power Wire (mm ²)		2.0 (<50 m)

Model		AHUKZ-02D~03D
Power	Phase	Single-phase
	Voltage and Frequency	220-240V – 50/60Hz
AHU Control Box Power Wire (mm ²)		4.0 (<50 m)

Caution Notes



- Specific wiring requirements must adhere to local wiring regulations.
- Use only copper wires.
- Be sure to use specified wires for connections and ensure that no external force is imparted to terminal connections. If connections are not firmly secured, overheating or fires may result.
- The wire size is the minimum value for metal conduit wiring. If the voltage drops, use a wire that is one rank thicker in diameter. Make sure the power-supply voltage does not drop by more than 10%.
- Power must be unified supply to all AHU control boxes in the same system
- A breaker for current leakage must be attached to the power supply. If no ground leakage breaker is installed, it may cause electrical shock
- Do not use anything other than a breaker and fuse with the correct capacity. Using a fuse or wire of too large capacity may cause malfunction or fire

12.10.5 Fan Wiring

Fan signal:

The AHU control box has two output modes to control fan speed: a signal output LOW/MIDDLE/HIGH and an output of 0-10V, respectively. The output mode is selected based on the actual on-site needs of the AHU.

Table 3-10

Fan Signal	LOW/ MIDDLE/HIGH	0-10V output
Low	LOW	*
Middle	MIDDLE	*
High	HIGH	*

Note: *Refer to 0-10V output control



0-10V output control

The DIP switch numbers of ENC2, ENC3 and ENC4 correspond to different voltage outputs. Depending on the DIP switch numbers of SW1-2, there are two control modes available, which are gear 1 and gear 3 fan speeds, respectively.

- SW1-2 dialled to "OFF" (by default)

ENC2, ENC3 and ENC4 are respectively defined as low, medium and high voltage output signals. By default, ENC2 is set to 2V, ENC3 is set to 7V, and ENC4 is set to A (A is 10V). See the table below for their corresponding relations:

Table 3-11

 ENC2 (2V Factory Default)					 ENC3 (7V Factory Default)						 ENC4 (10V Factory Default)					
Fan output voltage of Low speed					Fan output voltage of medium speed						Fan output voltage of high speed					
Dial Code	0	1	2	3	4	5	6	7	8	9	A	B	C	D	E	F
Voltage	1	1	2	3	4	5	6	7	8	9	10	10	10	10	10	10

Notes for installers



ENC2<ENC3<ENC4. If not satisfied, fault H9 is reported.

- SW1-2 dialled to "ON"

This indicates that the fan has only one fan speed. In this case, ENC2 indicates the fan speed while ENC3 indicates a 0-10V output voltage for the corresponding gear. ENC4 is not defined

ENC2 DIP	Fan Speed	LOW/MIDDLE/HIGH	0-10V output
0	Low only	LOW output	ENC3 voltage
1	Medium only	MIDDLE output	ENC3 voltage
2 (by default)	High only	HIGH output	ENC3 voltage
3-F	High only	HIGH output	ENC3 voltage

Corresponding voltage for the ENC3 DIP switch:

Table 3-13

Dial Code	0	1	2	3	4	5	6	7	8	9	A	B	C	D	E	F
Voltage	1	1	2	3	4	5	6	7	8	9	10	10	10	10	10	10

Wiring between the terminal block and fan

The sum current of the drainage pump and fan motor should not be greater than 3.5A in models AHUKZ-00D and AHUKZ-01D. The current of the drainage pump and fan motor should not be greater than 15A in models AHUKZ-02D and AHUKZ-03D.

The AHU control box has a control port for single-phase AC motor; refer to Figure 3-17 and Figure 3-18. It has three different speeds (high, medium, and low), the output voltage will also be the same as the input power of the box. Figure 3-17 and Figure 3-18 show the wiring diagram. Figure 3-17 recommends wiring in these two ways. In Figure 3-17, the AHU control box is not directly connected to the fan motor. Always use it as a motor driving the relay contacts. Only if the current value is greater than 3.5 A or 15A respectively, we would refer these models.

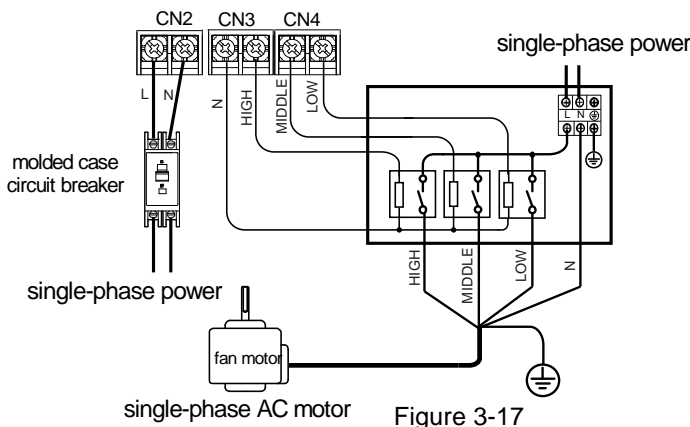

Figure 3-17

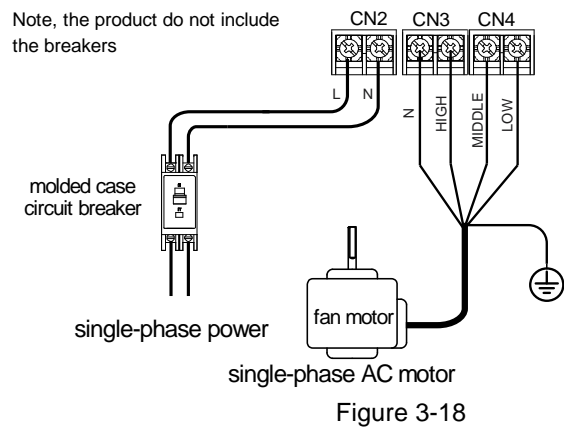

Figure 3-18

If wiring as shown in Figure 3-18, the maximum current of the fan motor must not exceed the value shown in Table 3-14.

Model	Max. Current of AC Motor and Drainage	Molded cases circuit breaker
AHUKZ-00D~01D	3.5A	6A
AHUKZ-02D~03D	15A	20A

If the fan motor is a 3-Phase AC motor, SW1-2 must be set to "ON", and the ENC2 must be dialled to "2". The fan terminal block only supports high-speed output. When wiring the motor, refer to Figure 3-19.

SW1, ENC2	
	Only high-speed is available

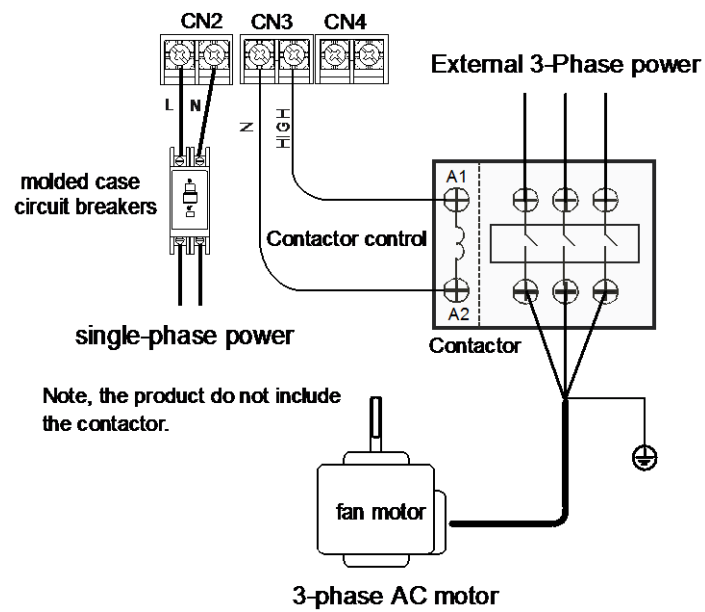

Figure 3-19

Notes for installers



- The rated current of the contactor must be greater than the current of the motor.
- The control power of the contactor must be the same as the input power of the AHU control box.
- SW1-2 must be set to "ON".
- ENC2 must be dialed to "2".

12.10.6 Signal Cable Connection

The following figure displays the signal cable connection diagram:

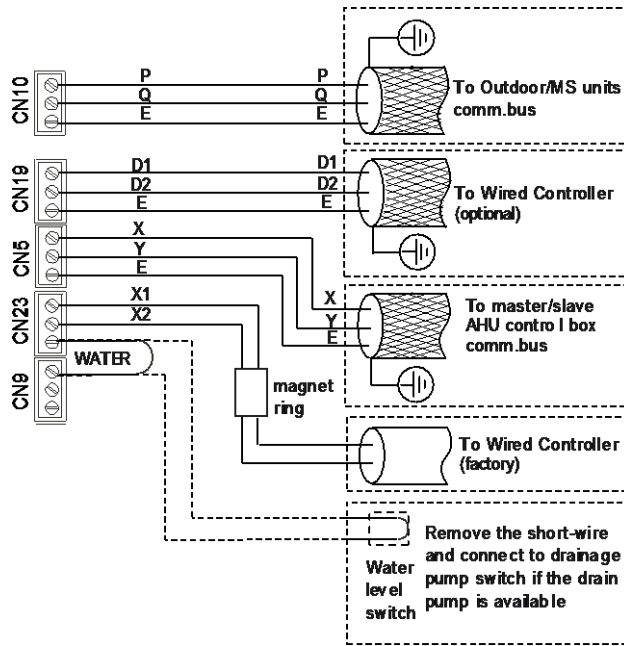
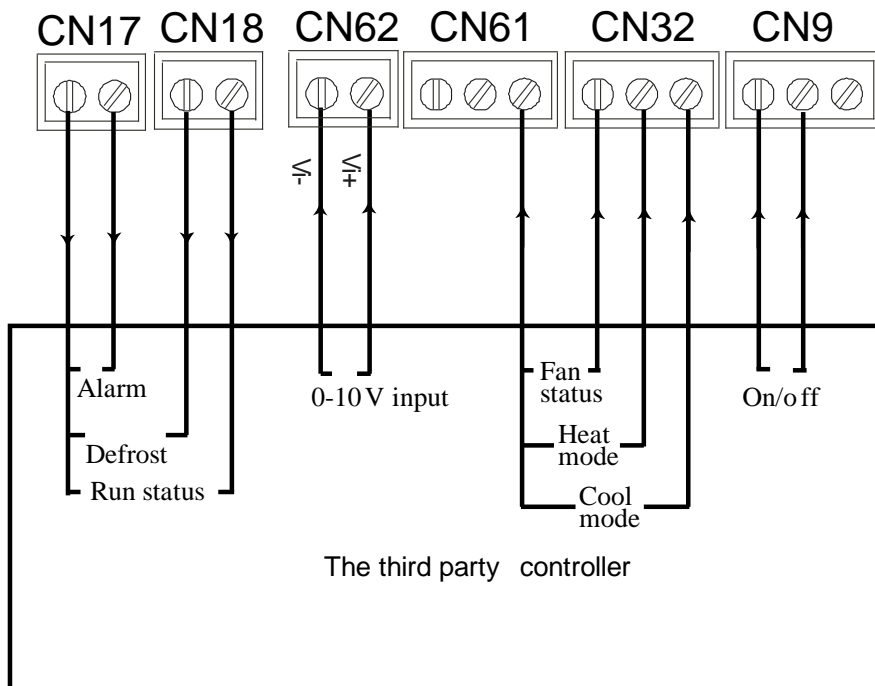

Figure 3-20

Note: The connecting terminals of the water level switch are connected by default. When connecting the AHU with the drainage pump, remove the connecting wire and connect to the water level switch.

X1 and X2 are ports for connecting to a standard wired controller, while D1 and D2 are ports for connecting to the optional wired controller. For specific models, consult the manufacturer's technical support personnel or a local dealer.

When a third party controller is used, communication between the AHU control box and third party controller is achieved via dry contacts. See the signal cable connection diagram below:



Example of signal wiring:

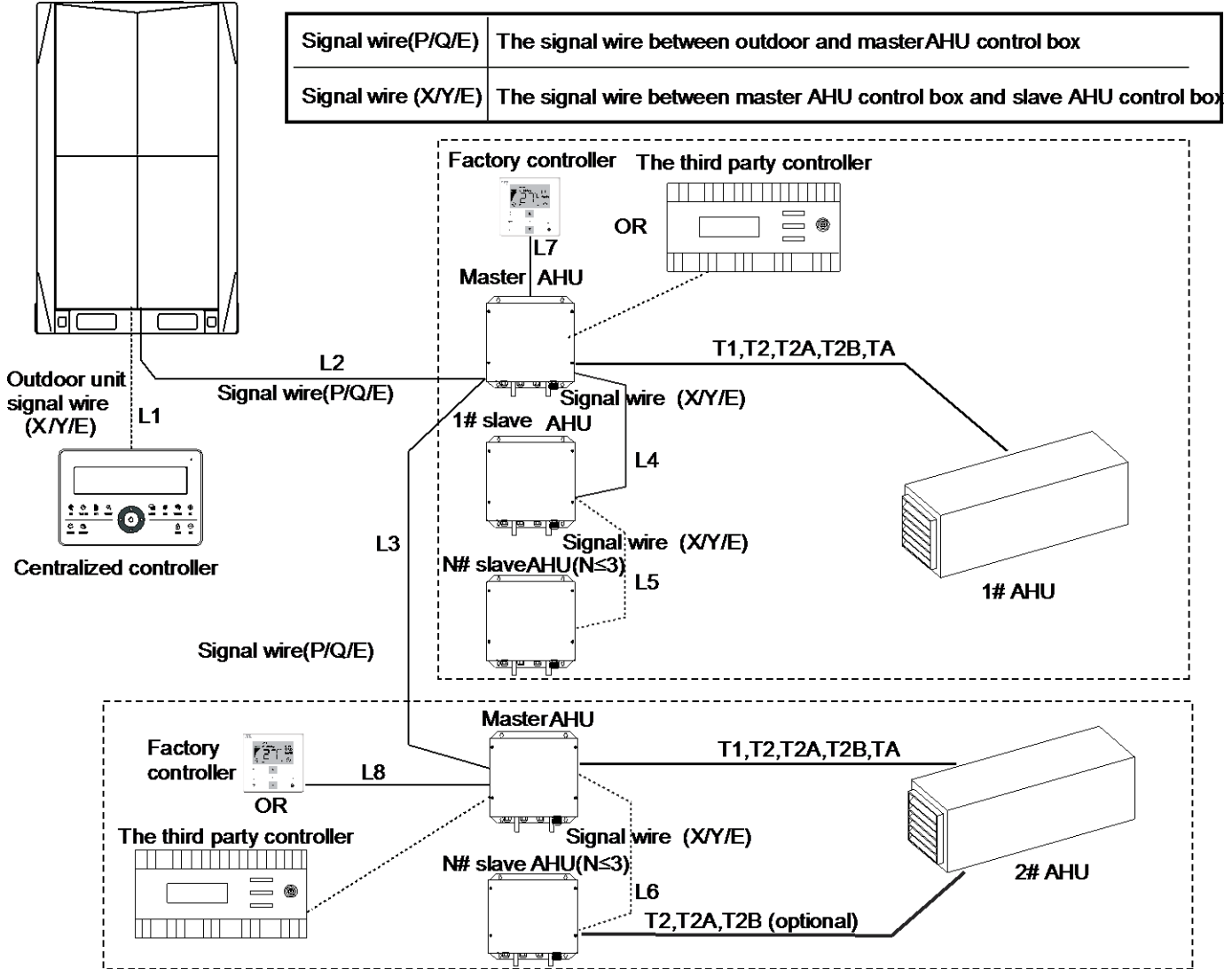
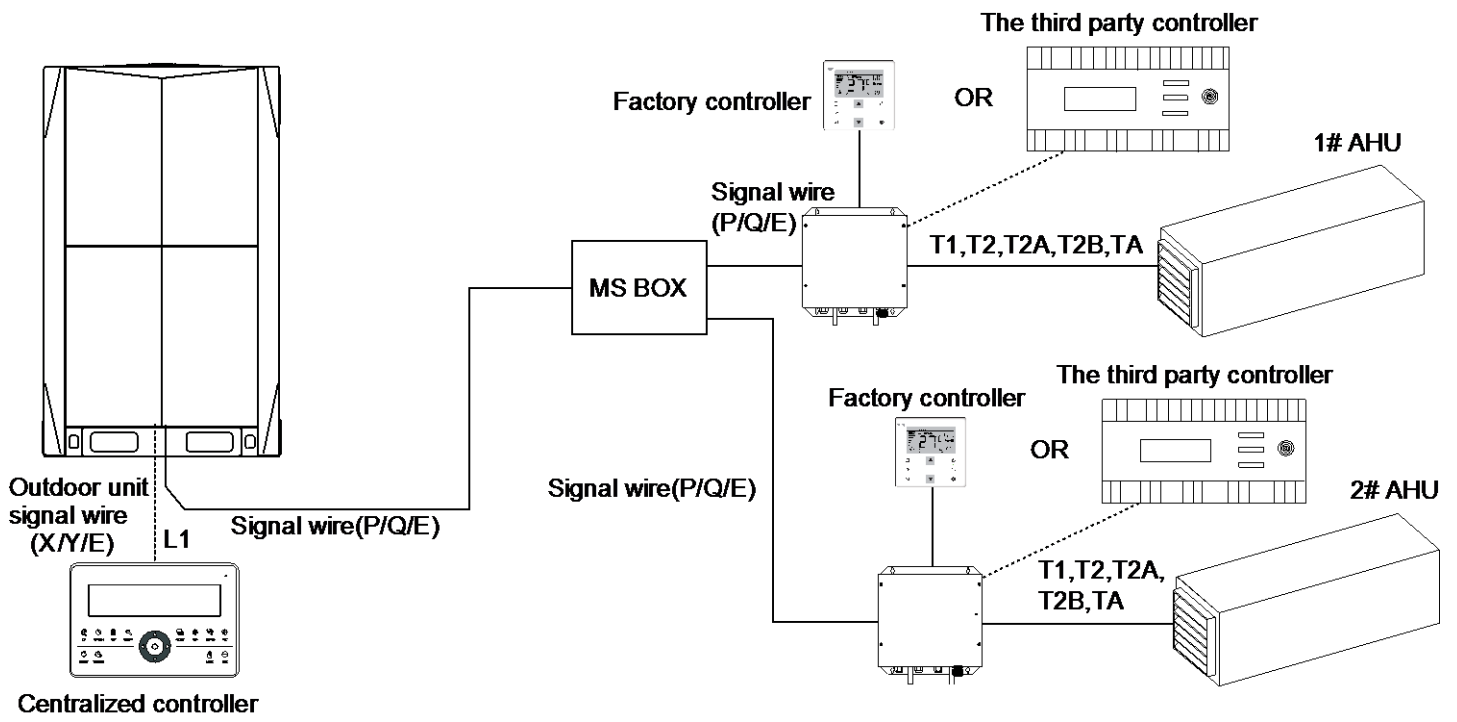

Figure 3-22

Note:

1. The diameter of the signal wire should be greater than or equal to 0.75 mm and the XY and PQ signal wire should be 2-core shielded wire.
2. Maximum wiring length: L1<1200m; L2+L3<1200m; L4+L5<1200m; L6<1200m.
3. When a third party DDC controller is selected, the DX AHU Control Box does not respond to the signal from Sinclair wire controller. However, Sinclair wire controller can be used to set the address and query parameters.
4. Connect the centralized controller to the ODU XY terminal block. Do not connect the centralized controller to the XY terminal block of the AHU control box.





12.11 Capacity Settings

The capacity DIP switches for the AHU control box should be set after the box is installed.

The capacity can be set through ENC1 and SW4-2. After completing the settings, power off and then power on the unit to apply the settings.



Note: Capacity settings must be done for each AHU control box in parallel connection

Table 4-1 Capacities of SW4-2 and ENC1

SW4-2 	ENC1 	Capacity (HP)	Capacity (kW)		
0	0	0.8 HP	2.2	AHUKZ-00D	
	1	1.0 HP	2.8		
	2	1.2 HP	3.2		
	3	1.7 HP	4.5		
	4	2.0 HP	5.6		
	5	2.5 HP	7.1		
	6	3.0 HP*	8.0		
	7	3.2 HP	9.0	AHUKZ-01D	
	8	3.6 HP	10.0		
	9	4.0 HP	11.2		
	A	4.5 HP	12.0		
	B	5.0 HP*	14.0		
	C	6.0 HP	16.0		
	1	D	6.5HP	18.0	AHUKZ-02D
		E	7.0hp	20.0	
		F	8.0 hp*	22.4	
0		10.0 hp	28.0	AHUKZ-03D	
1		12.0 hp	33.5		
2	14.0 hp	40.0			
3	16.0 hp	45.0			
	4	20.0 hp*	56.0		

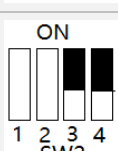

12.12 Setting the Master/ Slave AHU Control Box

- If multiple AHU control boxes are connected in parallel, the master/slave AHU control box needs to be set through SW2-3 and SW2-4.

 <p>ON 1 2 3 4 SW2</p>	<ul style="list-style-type: none"> SW2-3 and SW2-4 are 00: master AHU control box
 <p>ON 1 2 3 4 SW2</p>	<ul style="list-style-type: none"> SW2-3 and SW2-4 are 01: slave AHU control box 1
 <p>ON 1 2 3 4 SW2</p>	<ul style="list-style-type: none"> SW2-3 and SW2-4 are 10: slave AHU control box 2
 <p>ON 1 2 3 4 SW2</p>	<ul style="list-style-type: none"> SW2-3 and SW2-4 are 11: slave AHU control box 3

- When AHU control boxes are connected in parallel, the number of slave AHU control boxes must be set via SW1-3 and SW1-4.

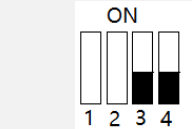
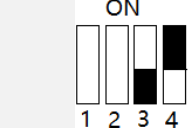
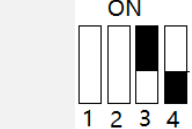
Note: The number of slave AHU control boxes connected in parallel can only be set from the main board of the master AHU control box.

 <p>ON 1 2 3 4</p> <p>Valid for the master unit only</p>	<ul style="list-style-type: none"> SW1-3 and SW1-4 are 00: 0 slave AHU control boxes (by default)
 <p>ON 1 2 3 4</p> <p>Valid for the master unit only</p>	<ul style="list-style-type: none"> SW1-3 and SW1-4 are 01: 1 slave AHU control box
 <p>ON 1 2 3 4</p> <p>Valid for the master unit only</p>	<ul style="list-style-type: none"> SW1-3 and SW1-4 are 10: 2 slave AHU control boxes
 <p>ON 1 2 3 4</p> <p>Valid for the master unit only</p>	<ul style="list-style-type: none"> SW1-3 and SW1-4 are 11: 3 slave AHU control boxes

12.13 Address Setting of AHU Control Box

When powering-on for the first time, If the address is not set, the wired controller will display fault E9. The ODU can use auto-addressing to set the address for an AHU control box which does not have an address.

If using manually setting up a wired controller is required to set the address of the AHU control box.

Only the master AHU control box communicates with the ODU. Therefore, only the address of master AHU control box needs to be set via the wired controller.

Press and hold ▲ and ▼ on the wired controller for 8s to enter the Address Settings page. If the AHU control box has an address, the page displays the current address. Otherwise, press ▲ and ▼ to change the address and press © to confirm and send the current address to the AHU control box.

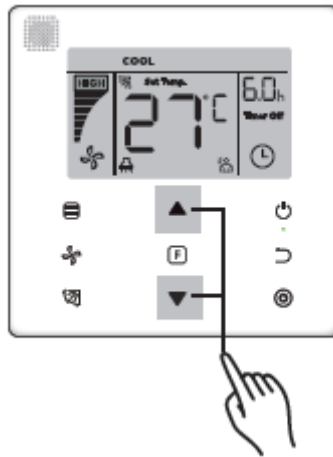

Note:

The address of the same system cannot be repeated.

When the AHU control box is set to have a capacity of over 18 kW and the capacity DIP switch is greater than D, a virtual address will be generated. The virtual address is equivalent to the actual address and occupies the address bit. When setting the address, do not set the actual address to a virtual address that is already occupied.

The master AHU control box calculates the total number of addresses occupied by AHU control boxes (represented by the letter N) based on the capacity of each AHU control box, and generates N-1 virtual addresses based on the set addresses.

SW4-2	ENC1	Corresponding Virtual Addresses					Quantity of Occupied Addresses
0	0~D	No virtual address					1
0	E-F	Actual address +1	/	/	/	/	2
1	0-1	Actual address +1	/	/	/	/	2
1	2-4	Actual address +1	Actual address +2	Actual address +3	/	/	4

12.13.1 Single AHU Control Box controlling one AHU

1. For SDV4 platform outdoor units, the address quantity of the AHU control box detected by the ODU will be the sum of the actual address quantity and the virtual address quantity. For example, if the capacity code of an AHU control box is E, and the actual setting address is 5, a virtual address 6 will be generated based on Table 4-2, and the quantity of IDUs detected by the ODU will be 2. If the ODU is not SDV4 platform ODU, the address quantity of the AHU control box detected by the ODU will be the sum of the actual address quantity.
2. When the AHU control box system connects to the centralized controller, the actual address and the virtual address will be displayed for SDV4 platform ODUs. For example, if the capacity code of an AHU control box is E and the actual setting address is 5, both the actual address 5 and the virtual address 6 will be displayed on the centralized controller. If the ODU is not a SDV4 platform ODU, only the actual address will be displayed
3. The network address is the same as the AHU control box address, so there is no need to set them separately.
4. Each individual AHU control box controls one AHU. Each individual AHU control box is the main AHU control box.

12.13.2 Several AHU Control Boxes in a parallel connection controlling one AHU



For this product, several AHU control boxes are allowed to connect in parallel to control one AHU. In this case, three steps must be completed.

- Set the main AHU control box, slave 1 AHU control box, slave 2 AHU control box, and slave 3 AHU control box by using SW2-3 and SW2-4.
- Set the quantity of slave AHU control boxes by using SW1-3 and SW1-4.
- Set an address on the main AHU control box by a wired controller. This address is an actual address. Virtual addresses will be generated in the parallel connection system.

If there are several parallel AHU control box systems in one refrigerant system, calculate the number of occupied virtual addresses for each parallel AHU control box system, and set the actual address of each parallel AHU control box system to avoid repetition of actual addresses and virtual addresses.

12.13.3 Selection of control by return air temperature



An AHU control box can select the control by either return air temperature or by outlet air temperature via SW4-1.

SW4-1	
	SW4-1 OFF return air temperature control (by default)
	SW4-1 ON outlet air temperature control

When return air temperature control is selected, a return air temperature sensor must be connected; when outlet air temperature control is selected, both the return air temperature sensor and outlet air temperature sensor must be connected.

13 Selection of Controllers

The factory controller or a third party controller can be selected for the AHU control box. The type of controllers can be selected through SW4-3 and SW4-4.

SW4-3, SW4-4	Controller Category
	SW4-3 and SW4-4 are 00: factory controller mode (by default)
	SW4-3 and SW4-4 are 01: capacity output mode of a third party controller
	SW4-3 and SW4-4 are 10: set temperature control mode of third party controller

Note: After DIP switches on main board are set, remember to power off and then power on the main board to apply the settings. Otherwise, the settings will be invalid.

When a third party controller is used, two control modes are available: capacity output control mode and set temperature control mode.

13.1 Factory Controller

When the factory controller is selected, the AHU control box can be controlled by the factory wired controller or remote controller.

The factory wired controller in the accessories is connected to X1 and X2 ports on the main board.

Only the master AHU control box communicates with the ODU. As a result, when AHU control boxes are connected in parallel, the factory wired controller only needs to be connected to X1 and X2 of the master AHU control box.

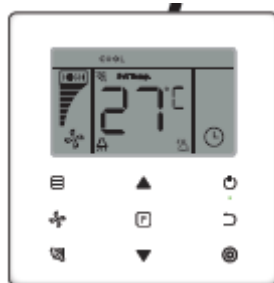

Figure 5-1 Factory wired controller

For detailed instructions for the wired controller, refer to the wired controller installation & owner’s manual.

Note: When the factory controller mode is applied, the main board of the AHU control box will not respond to the control signal from a third party controller.

13.1.1 Setting Capacity Output Mode via Third party controller (Type 1)

When capacity setting with a third party controller mode has been selected, only the third party controller can be used to control the AHU control box. The signal from the factory controller will not respond except to the address setting and inquiring signal.

Even if capacity setting with third party controller mode has been selected, a factory remote controller or wired controller is needed to set the address for the AHU control box, because the third party controller does not have this function.

Wiring figure

For the wiring figure, refer to Figure 3-21. Pay careful attention to the following three things:

1. The distance between the third party controller and the AHU control box depends on the external device that is connected (controller/relay...)
2. If several AHU control boxes in a parallel connection control one AHU, the third party controller only needs to be connected with the master AHU control box.
3. One third party controller cannot control two or more AHU at the same time.

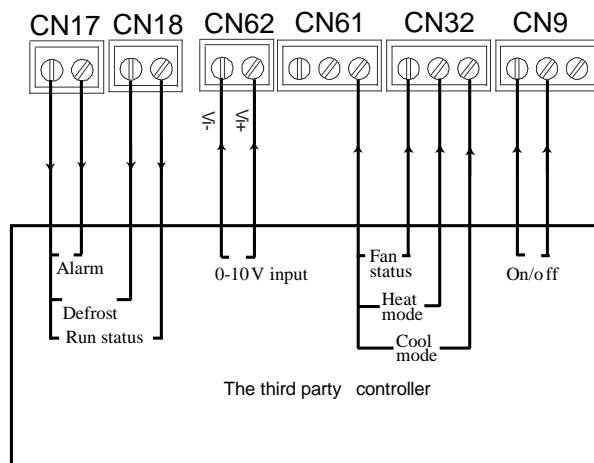

The definition of signals between the third party controller and AHU control box.

1. Signals from the third party controller to the AHU control box.

Signal	Signal Type	Specification	Port
Capacity set	Analog voltage	0-10VDC	0-10V input
ON/OFF	Dry contact	Close: ON Disconnect: OFF	ON/OFF
Cool mode	Dry contact	Close: cool mode Disconnect: no cool signal	COOL
Heat mode	Dry contact	Close: heat mode Disconnect: no heat signal	HEAT
Fan status	Dry contact	Close: fan ON Disconnect: fan OFF	FAN

Note:

- (1) The analog voltage must be between the maximum and the minimum value.
- (2) Don't close the heat mode contact and cool mode contact at the same time if it needs to run the AHU control box.

2. Signals from the AHU control box to the third party controller

Signal	Signal Type	Specification	Port
Alarm	Dry contact	Close: alarm Disconnect: no alarm	Alarm
Defrost	Dry contact	Close: defrosting or anticold wind protection Disconnect: no defrost	Defrost
Run status	Dry contact	Close: running Disconnect: off	Run

Note:

1. All signals between the third party controller and AHU control box must be in accordance with the definition specified in Table 5-1 and Table 5-2. It will not work correctly if the definition of the signal in the third party controller is not correct.

Operation at 0-10V capacity output

This control mode requires a third party controller equipped with a temperature sensor that is used to control the following temperatures:

1. Return air temperature of the AHU
2. Outlet air temperature of the AHU

The AHU control box will interpret the 0–10 V signal according to 10 steps. The correlation between the voltage output and the AHU capacity requirement is shown in the table below:

Capacity Setting requirement table (Same in Heating and Cooling)		
Analog input 0-10V DC		Capacity Setting Requirement
Normal(V)	Range(V)	
0	$U < 0.5$	0%
1	$0.5 \leq U < 1.5$	10%
2	$1.5 \leq U < 2.5$	20%
3	$2.5 \leq U < 3.5$	30%
4	$3.5 \leq U < 4.5$	40%
5	$4.5 \leq U < 5.5$	50%
6	$5.5 \leq U < 6.5$	60%
7	$6.5 \leq U < 7.5$	70%
8	$7.5 \leq U < 8.5$	80%
9	$8.5 \leq U < 9.5$	90%
10	$9.5 \leq U < 10$	100%

Operation Instruction

When the third party controller has been selected, AHU control box will operate according to the control signal from the third party controller and output alarm, defrost and run status signal.

13.1.2 Setting Temperature Mode via third party controller (Type 2)

When temperature is controllable by a third party controller, the AHU control box does not respond to instructions from the factory controller except for address setting and query.

Even if temperature control by a third party controller is applied, a factory controller is still needed to set the address because the third party controller cannot do so.

Third party controller wiring

Please refer to Figure 3-21 for the wiring diagram. Pay careful attention to the following three things:

1. The distance between the third party controller and the AHU control box depends on the external device that is connected (controller/relay...)
2. If several AHU control boxes in parallel connection control one AHU, the third party controller only needs to be connected with the master AHU control box.

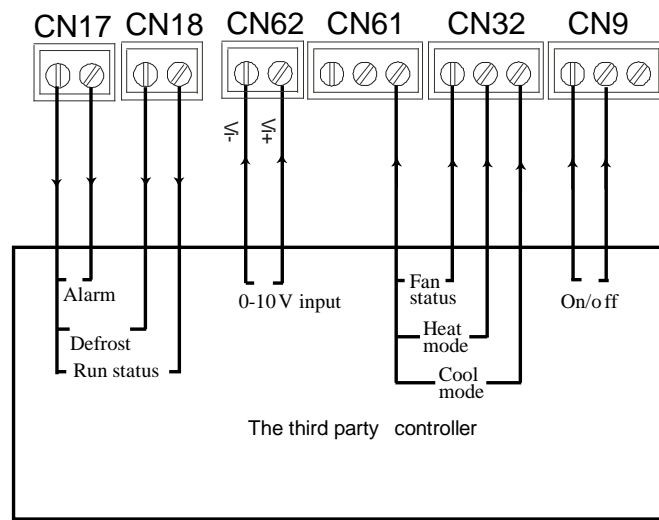

3. One third party controller can't control two or more AHUs at the same time.

Definition of signals between the third party controller and the AHU control box

1. Signals from the third party controller to the AHU control box.

Signal	Signal Type	Specification	Port
Temp. set	Analog voltage	0~10VDC refer to Table 6-3	0-10V input
ON/OFF	Dry contact	Close: ON Disconnect: OFF	ON/OFF
Cool mode	Dry contact	Close: cool mode Disconnect: no cool signal	COOL
Heat mode	Dry contact	Close: heat mode Disconnect: no heat signal	HEAT
Fan status	Dry contact	Close: fan ON Disconnect: fan OFF	FAN

Note:

- (1) The analog voltage must be between the maximum and the minimum value.
 - (2) Don't close the heat mode contact and cool mode contact at the same time if it needs to run the AHU control box.
2. Signals from the AHU control box to the third party controller.

Signal	Signal Type	Specification	Port
Alarm	Dry contact	Close: alarm Disconnect: no alarm	Alarm
Defrost	Dry contact	Close: defrosting or anti-cold wind protection Disconnect: no defrost	Defrost
Run status	Dry contact	Close: running Disconnect: off	Run

Note:

- 1. The definition of signals between the third party controller and AHU control box must comply with those shown in Table 5-5 and Table 5-6. If the signal is incorrectly defined, the system will not operate properly.

Operation at 0-10V temperature output

- The AHU control box needs to be connected to the return air temperature sensor T1, and to be connected to the outlet air temperature sensor TA if the outlet air temperature control is selected.
- The third party controller sends a voltage signal of 0-10V to the AHU control box. The AHU control box converts the voltage of 0-10V into the target temperature TS according to Table 5-7 or Table 5-8, and calculates the temperature difference between the target temperature and the return temperature T1 or the outlet temperature TA detected by the AHU control box. The temperature difference is used to regulate the system output.

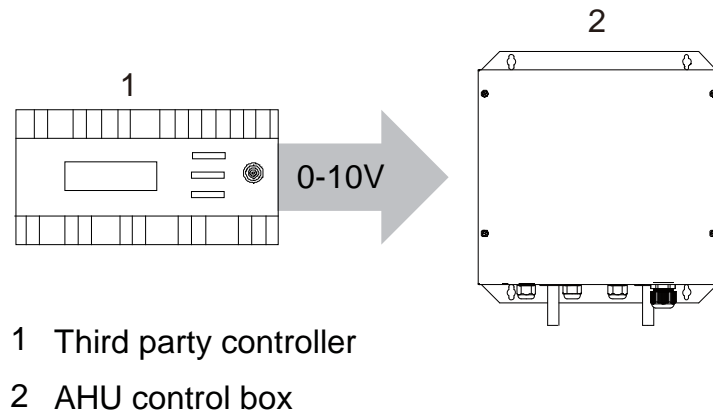

- 1 Third party controller
- 2 AHU control box

Figure 5-3

- 1. Third party controller
- 2. AHU control box

Third party controller - return air temperature control setting







Normal	Voltage Range		Cooling Set Temperature (°C)	Heating Set Temperature (°C)
	Min.	Max.		
0.5	0	0.75	Not available	Not available
1	0.85	1.15	17	17
1.4	1.25	1.55	17	17
1.8	1.65	1.95	17	17
2.2	2.05	2.35	17	17
2.6	2.45	2.75	17	17
3	2.85	3.15	17	17
3.4	3.25	3.55	17	17
3.8	3.65	3.95	17	17
4.2	4.05	4.35	18	18
4.6	4.45	4.75	19	19
5	4.85	5.15	20	20
5.4	5.25	5.55	21	21
5.8	5.65	5.95	22	22
6.2	6.05	6.35	23	23
6.6	6.45	6.75	24	24
7	6.85	7.15	25	25
7.4	7.25	7.55	26	26
7.8	7.65	7.95	27	27
8.2	8.05	8.35	28	28
8.6	8.45	8.75	29	29
9	8.85	9.15	30	30
9.4	9.25	10	Not available	Not available

Third party controller - outlet air temperature control setting				
Normal	Voltage Range		Cooling Set Temperature (°C)	Heating Set Temperature (°C)
	Min.	Max.		
0.5	0	0.75	Non settable	Non settable
1	0.85	1.15	10	10
1.4	1.25	1.55	11	11
1.8	1.65	1.95	12	12
2.2	2.05	2.35	13	13
2.6	2.45	2.75	14	14
3	2.85	3.15	15	15
3.4	3.25	3.55	16	16
3.8	3.65	3.95	17	17
4.2	4.05	4.35	18	18
4.6	4.45	4.75	19	19
5	4.85	5.15	20	20
5.4	5.25	5.55	21	21
5.8	5.65	5.95	22	22
6.2	6.05	6.35	23	23
6.6	6.45	6.75	24	24
7	6.85	7.15	25	25
7.4	7.25	7.55	26	26
7.8	7.65	7.95	27	27
8.2	8.05	8.35	28	28
8.6	8.45	8.75	29	29
9	8.85	9.15	30	30
9.4	9.25	10	Non settable	Non settable

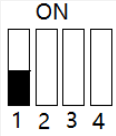

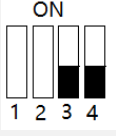

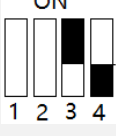

Note: The analog voltage must be between maximum and minimum value.

14 Dip Switch definitions



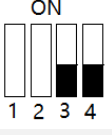

1) Definitions of each bit of SW1:

 <p>Valid for the master unit only</p>	<ul style="list-style-type: none"> SW1-1 is 0: shutdown compensation temperature (cooling) is 0°C (factory default) SW1-1 is 1: shutdown compensation temperature (cooling) is 2°C (outlet air temperature control is invalid)
 <p>Valid for the master unit only</p>	<ul style="list-style-type: none"> SW1-2 is 0: AHU control box provides three fan speeds (factory default) SW1-2 is 1: only high fan speed
 <p>Valid for the master unit only</p>	<ul style="list-style-type: none"> SW1-3 and SW1-4 are 00: the number of slave AHU control boxes connected in parallel is 0 (factory default); valid for the master unit
 <p>Valid for the master unit only</p>	<ul style="list-style-type: none"> SW1-3 and SW1-4 are 01: the number of slave AHU control boxes connected in parallel is 1
 <p>Valid for the master unit only</p>	<ul style="list-style-type: none"> SW1-3 and SW1-4 are 10: the number of slave AHU control boxes connected in parallel is 2
 <p>Valid for the master unit only</p>	<ul style="list-style-type: none"> SW1-3 and SW1-4 are 11: the number of slave AHU control boxes connected in parallel is 3



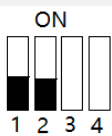

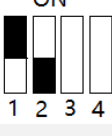

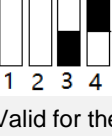
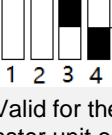
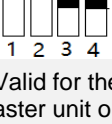
2) Definitions of each bit of SW2:

 <p>ON 1 2 3 4</p>	<ul style="list-style-type: none"> • SW2-1 is 0: automatic addressing (factory default) • SW2-1 is 1: clearing AHU control box address
 <p>ON 1 2 3 4</p>	<ul style="list-style-type: none"> • SW2-2 is 0: no self-check (factory default) • SW2-2 is 1: self-check
 <p>ON 1 2 3 4</p>	<ul style="list-style-type: none"> • SW2-3 and SW2-4 are 00: master AHU control box
 <p>ON 1 2 3 4</p>	<ul style="list-style-type: none"> • SW2-3 and SW2-4 are 01: slave AHU control box 1
 <p>ON 1 2 3 4</p>	<ul style="list-style-type: none"> • SW2-3 and SW2-4 are 10: slave AHU control box 2
 <p>ON 1 2 3 4</p>	<ul style="list-style-type: none"> • SW2-3 and SW2-4 are 11: slave AHU control box 3

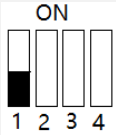

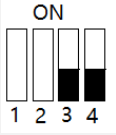
3) Definitions of each bit of SW3:

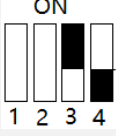
	Return Air Temperature Control (SW4-1: 0)	Outlet Air Temperature Control (SW4-1: 1)
 <p>Valid for the master unit only</p>	<ul style="list-style-type: none"> SW3-1 and SW3-2 are 00: anti-cold air temperature value in heating mode is 15°C (factory default) 	<ul style="list-style-type: none"> SW3-1 and SW3-2 are 00: anti-cold air temperature value in heating mode is 14°C (factory default)
 <p>Valid for the master unit only</p>	<ul style="list-style-type: none"> SW3-1 and SW3-2 are 01: anti-cold air temperature value in heating mode is 20°C 	<ul style="list-style-type: none"> SW3-1 and SW3-2 are 01: anti-cold air temperature value in heating mode is 12°C
 <p>Valid for the master unit only</p>	<ul style="list-style-type: none"> SW3-1 and SW3-2 are 10: anti-cold air temperature value in heating mode is 24°C 	<ul style="list-style-type: none"> SW3-1 and SW3-2 are 10: anti-cold air temperature value in heating mode is 16°C
 <p>Valid for the master unit only</p>	<ul style="list-style-type: none"> SW3-1 and SW3-2 are 11: anti-cold air temperature value in heating mode is 26°C 	<ul style="list-style-type: none"> SW3-1 and SW3-2 are 11: anti-cold air temperature value in heating mode is 18°C
 <p>Valid for the master unit only</p>	<ul style="list-style-type: none"> SW3-3 and SW3-4 are 00: temperature compensation in heating mode is 6°C (factory default) 	<ul style="list-style-type: none"> SW3-3 and SW3-4 are 00: Outlet air temperature control is invalid
 <p>Valid for the master unit only</p>	<ul style="list-style-type: none"> SW3-3 and SW3-4 are 01: temperature compensation in heating mode is 2°C 	<ul style="list-style-type: none"> SW3-3 and SW3-4 are 01: Outlet air temperature control is invalid
 <p>Valid for the master unit only</p>	<ul style="list-style-type: none"> SW3-3 and SW3-4 are 10: temperature compensation in heating mode is 4°C 	<ul style="list-style-type: none"> SW3-3 and SW3-4 are 10: Outlet air temperature control is invalid
 <p>Valid for the master unit only</p>	<ul style="list-style-type: none"> SW3-3 and SW3-4 are 11: temperature compensation in heating mode is 0°C (Follow Me function) 	<ul style="list-style-type: none"> SW3-3 and SW3-4 are 11: No temperature compensation for outlet air temperature control by default

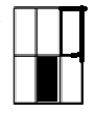

4) Definitions of each bit of SW4:

 <p>Valid for the master unit only</p>	<ul style="list-style-type: none"> SW4-1 is 0: return air temperature control (factory default) SW4-1 is 1: outlet air temperature control
	<ul style="list-style-type: none"> SW4-2 indicates high bit (ON indicates + 16)
 <p>Valid for the master unit only</p>	<ul style="list-style-type: none"> SW4-3 and SW4-4 are 00: factory controller mode (factory default)
 <p>Valid for the master unit only</p>	<ul style="list-style-type: none"> SW4-3 and SW4-4 are 01: capacity output mode of a third party controller
 <p>Valid for the master unit only</p>	<ul style="list-style-type: none"> SW4-3 and SW4-4 are 10: set temperature control mode of a third party controller
 <p>Valid for the master unit only</p>	<ul style="list-style-type: none"> SW4-3 and SW4-4 are 11: set temperature control mode of a third party controller (reserved)

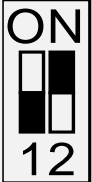

5) Definitions of each bit of SW9:

<p style="text-align: center;">ON</p>  <p>Valid for the master unit only</p>	<ul style="list-style-type: none"> • SW9-1 is 0: 2-digit digital display panel (factory default) • SW9-2 is 1: 3-digit digital display panel
<p style="text-align: center;">ON</p>  <p>Valid for the master unit only</p>	<ul style="list-style-type: none"> • SW9-2 is 0: mode 1 of AHU control box connecting to valve body in parallel (one coil is connected to multiple control boxes; shielding faults from the slave unit's temperature sensors T1, T2, T2A and T2B) (factory default) • SW9-2 is 1: mode 2 of the AHU control box connecting to valve body in parallel (in the event of multiple coils, one coil is connected to one control box; shielding faults from the slave unit's temperature sensor T1)
<p style="text-align: center;">ON</p>  <p>Valid for the master unit only</p>	<ul style="list-style-type: none"> • SW9-3 is 0: no swing control (Factory default) • SW9-3 is 1: swing control

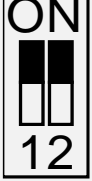
6) Definitions of each bit of SW10:

	<ul style="list-style-type: none"> • 00: AHUKZ-00D model
	<ul style="list-style-type: none"> • 01: AHUKZ-01D model
	<ul style="list-style-type: none"> • 10: AHUKZ-02D model
	<ul style="list-style-type: none"> • 11: AHUKZ-03D model

7) Definitions of J1:

 <p>J1</p>	<ul style="list-style-type: none"> • Without jumper; no short circuit indicates a power failure memory function (factory default)
 <p>J1</p>	<ul style="list-style-type: none"> • With jumper, short circuit indicates no power failure memory function

15 Error Code and Query

15.1 Error Code Table









Priority	Definition	Displayed Content
1	Refrigerant leak error	A1
2	Emergency Shutdown	A0
3	No address is set	FE(Only displayed on the display board)
4	IDU address code repeated- F7+repeated address, displayed alternately every 1 sec	F7+repeated address
5	Mode Conflict error	E0
6	Communication error between IDU and ODU	E1
7	T1 sensor error	E2
8	T2 sensor error	E3
9	T2B sensor error	E4
10	T2A sensor error	E5
11	TA sensor error	E8 (the error is not reported when return air temperature control is applied)
12	IDU fan error	E6 (reserved)
13	EEPROM error	E7
14	Communication error with the wired controller	E9 (only for wired controller)
15	Error of electronic expansion valve coils	Eb
16	ODU Error	Ed
17	Low temperature alarm	H2
18	High temperature alarm	H3
19	Number of AHU control boxes detected is inconsistent with number of dialed sets or communication error between master and slave units	H6
20	Capacity DIP switch of the AHU control box is inconsistent with the model/total parallel capacity out of range	H8 (restored after power-on)
21	(ENC2, ENC3, ENC4) incorrect DIP switch for 0-10V fan signal. The DIP switch value ensures ENC2 < ENC3 < ENC4	H9
22	Pressure sensor error	P1 (reserved)
23	Water level alarm error	EE
24	MS error mode	F8
25	MS self-check error	U4 (restore after power on again)
26	Slave unit error	Hb (only displayed on the display board, not sent to a centralized or wired controller)
27	Water Level Alarm	EE

15.2 Query

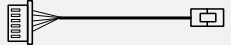
Wired controller query

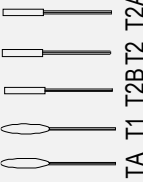
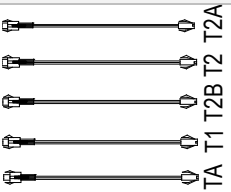
No.	No. Parameter displayed on the wired controller during control box check
1	Control box address
2	Capacity (HP) of control box
3	Control box network address (the same as the address)
4	Set temperature Ts
5	Room temperature T1
6	T2 Sensor Value
7	T2A Sensor Value
8	T2B Sensor Value
9	Ta temperature
10	Target superheat degree (reserved)
11	EXV position/8
12	Software version No.
13	Error Code

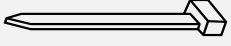
16 Accessories

Name	Shape	Quantity	Function
Installation & Owner's Manual		1	-
Wired controller		1	Wired controller
Electronic Expansion valve extension cable		1	-
Fixed clamp of temperature sensor		3	-
Temperature sensors	 TA T1 T2B T2 T2A	5	-
Temperature sensors extension cables	 TA T1 T2B T2 T2A	5	-
Screw ST 3.9x25		8	Secure the installation board
Plastic expanded tube		8	-
Zip Tie		5	-
SIEXVe		3	-

17 Appendix

17.1 Temperature Sensor Resistance Characteristics

Temperature (°C)	Resistance (kΩ)	Temperature (°C)	Resistance (kΩ)	Temperature (°C)	Resistance (kΩ)	Temperature (°C)	Resistance (kΩ)
-20	115.3	20	12.64	60	2.358	100	0.6297
-19	108.1	21	12.06	61	2.272	101	0.6115
-18	101.5	22	11.50	62	2.191	102	0.5939
-17	96.34	23	10.97	63	2.112	103	0.5768
-16	89.59	24	10.47	64	2.037	104	0.5604
-15	84.22	25	10.00	65	1.965	105	0.5445
-14	79.31	26	9.551	66	1.896	106	0.5291
-13	74.54	27	9.124	67	1.830	107	0.5143
-12	70.17	28	8.720	68	1.766	108	0.4999
-11	66.09	29	8.336	69	1.705	109	0.4860
-10	62.28	30	7.971	70	1.647	110	0.4726
-9	58.71	31	7.624	71	1.591	111	0.4596
-8	56.37	32	7.295	72	1.537	112	0.4470
-7	52.24	33	6.981	73	1.485	113	0.4348
-6	49.32	34	6.684	74	1.435	114	0.4230
-5	46.57	35	6.400	75	1.387	115	0.4116
-4	44.00	36	6.131	76	1.341	116	0.4006
-3	41.59	37	5.874	77	1.291	117	0.3899
-2	39.82	38	5.630	78	1.254	118	0.3796
-1	37.20	39	5.397	79	1.2133	119	0.3695
0	35.20	40	5.175	80	1.174	120	0.3598
1	33.33	41	4.964	81	1.136	121	0.3504
2	31.56	42	4.763	82	1.100	122	0.3413
3	29.91	43	4.571	83	1.064	123	0.3325
4	28.35	44	4.387	84	1.031	124	0.3239
5	26.88	45	4.213	85	0.9982	125	0.3156
6	25.50	46	4.046	86	0.9668	126	0.3075
7	24.19	47	3.887	87	0.9366	127	0.2997
8	22.57	48	3.735	88	0.9075	128	0.2922
9	21.81	49	3.590	89	0.8795	129	0.2848
10	20.72	50	3.451	90	0.8525	130	0.2777
11	19.69	51	3.318	91	0.8264	131	0.2708
12	18.72	52	3.192	92	0.8013	132	0.2641
13	17.80	53	3.071	93	0.7771	133	0.2576
14	16.93	54	2.959	94	0.7537	134	0.2513
15	16.12	55	2.844	95	0.7312	135	0.2451
16	15.34	56	2.738	96	0.7094	136	0.2392
17	14.62	57	2.637	97	0.6884	137	0.2334
18	13.92	58	2.540	98	0.6682	138	0.2278
19	13.26	59	2.447	99	0.6486	139	0.2223

NOTE CONCERNING PROTECTION OF ENVIRONMENT



This product must not be disposed of via normal household waste after its service life, but must be taken to a collection station for the recycling of electrical and electronic devices. The symbol on the product, the operating instructions or the packaging indicate such disposal procedures. The materials are recyclable in accordance with their respective symbols. By means of re-use, material recycling or any other form of recycling old appliances you are making an important contribution to the protection of our environment. Please ask your local council where your nearest disposal station is located.

INFORMATION CONCERNING USED REFRIGERANT MEDIUM

This unit is containing fluorinated gases included in the Kyoto protocol. The maintenance and the liquidation must be carried out by qualified personnel.

Type of refrigerant: R410A

The composition of the cooling medium R410A: (50% HFC-32, 50% HFC-125)

The quantity of the refrigerant: please see the unit label.

The value GWP: 2088 (1 kg R410A = 2,088 t CO₂ eq)

GWP = Global Warming Potential

In case of quality problem or other please contact your local supplier or authorized service center.

Emergency number: 112

PRODUCER

SINCLAIR CORPORATION Ltd.

1-4 Argyll St.

London W1F 7LD

Great Britain

www.sinclair-world.com

This product was manufactured in China (Made in China).

REPRESENTATIVE

SINCLAIR Global Group s.r.o.

Purkynova 45

612 00 Brno

Czech Republic

TECHNICAL SUPPORT

SINCLAIR Global Group s.r.o.

Purkynova 45

612 00 Brno

Czech Republic

Tel.: +420 800 100 285

Fax: +420 541 590 124

www.sinclair-solutions.com

info@sinclair-solutions.com

